

Release 2.0

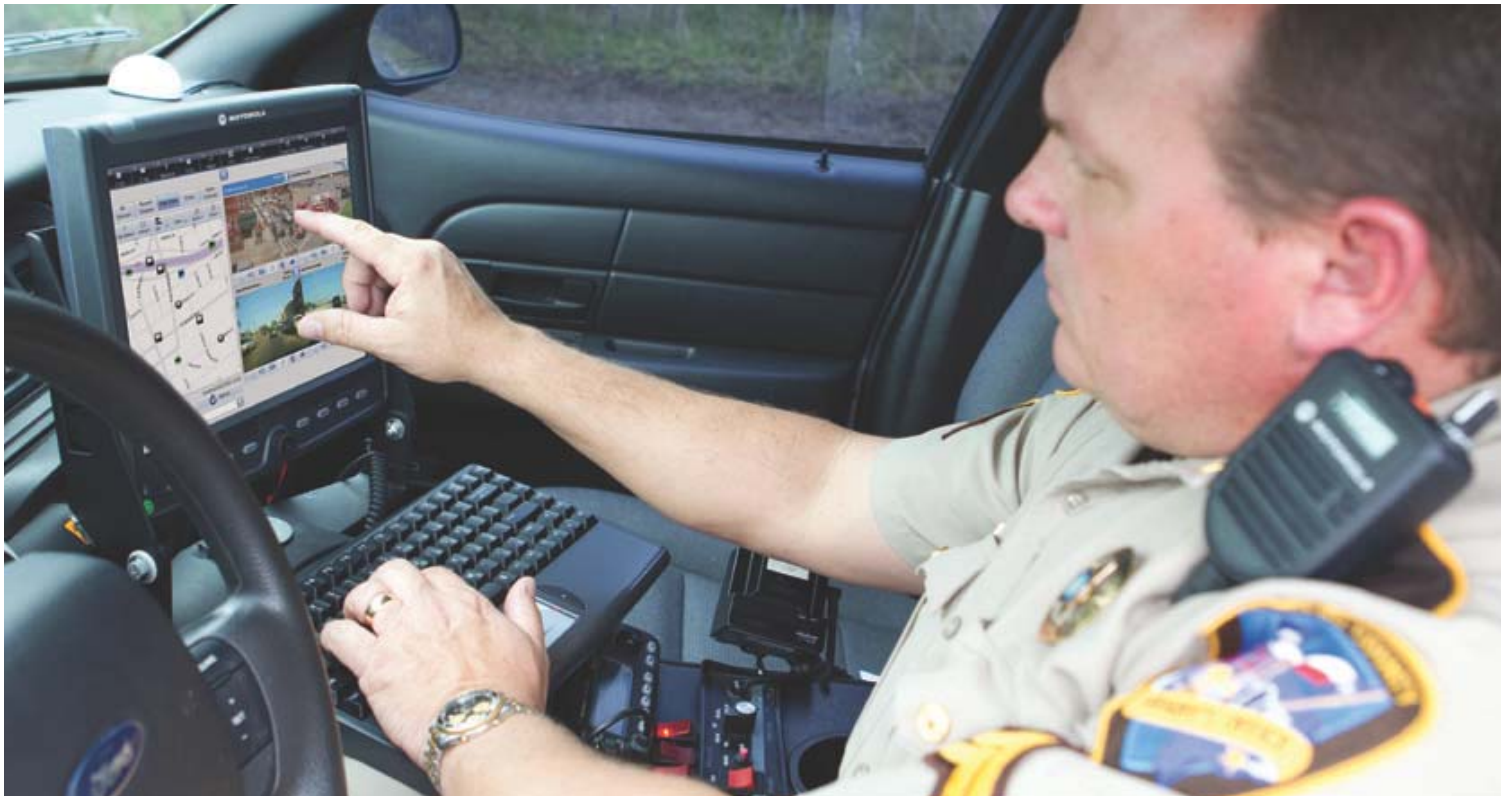

MW810 MOBILE WORKSTATION MODEL F5218 VEHICLE INSTALLATION MANUAL



July 2012

© 2012 Motorola Solutions, Inc. All rights reserved.

6802988C56-A



COMPUTER SOFTWARE COPYRIGHTS

The Motorola Solutions products described in this instruction manual may include copyrighted Motorola Solutions computer programs stored in semiconductor memories or other media. Laws in the United States and other countries preserve for Motorola Solutions certain exclusive rights for copyrighted computer programs, including the exclusive right to copy or reproduce in any form the copyrighted computer program. Accordingly, any copyrighted Motorola Solutions computer programs contained in the Motorola Solutions products described in this instruction manual may not be copied or reproduced in any manner without the express written permission of Motorola Solutions. Furthermore, the purchase of Motorola Solutions products shall not be deemed to grant either directly or by implication, estoppel or otherwise, any license under the copyrights, patents or patent applications of Motorola Solutions, except for the normal non-exclusive, royalty free license to use that arises by operation of law in the sale of a product.

EPS – 34440- B

LIMITED WARRANTY

MOTOROLA SOLUTIONS MW810 MOBILE WORKSTATION

If any affected product is being purchased in response to a Motorola Solutions proposal containing a different communication products warranty, the warranty contained in that proposal will apply to such affected product. Otherwise, the following warranty applies.

I. WHAT THIS WARRANTY COVERS AND FOR HOW LONG:

Motorola Solutions Inc. or, if applicable, Motorola Solutions Canada Limited ("Motorola Solutions") warrants the Motorola Solutions MW810 Mobile Workstation ("Product") against material defects in material and workmanship under normal use and service for a period of Three (3) Years from the date of shipment.

Motorola Solutions, at its option, will at no charge either repair the Product (with new or reconditioned parts), replace it with the same or equivalent Product (using new or reconditioned Product), or refund the purchase price of the Product during the warranty period provided purchaser notifies Motorola Solutions according to the terms of this warranty. Repaired or replaced Product is warranted for the balance of the original applicable warranty period. All replaced parts of the Product shall become the property of Motorola Solutions.

This express limited warranty is extended by Motorola Solutions to the original end user purchaser purchasing the Product for purposes of leasing or for commercial, industrial, or governmental use only, and is not assignable or transferable to any other party. This is the complete warranty for the Product manufactured by Motorola Solutions. Motorola Solutions assumes no obligations or liability for additions or modifications to this warranty unless made in writing and signed by an officer of Motorola Solutions. Unless made in a separate written agreement between Motorola Solutions and the original end user purchaser, Motorola Solutions does not warrant the installation, maintenance or service of the Product.

Motorola Solutions cannot be responsible in any way for any ancillary equipment not furnished by Motorola Solutions, which is attached to or used in connection with the Product, or for operation of the Product with any ancillary equipment, and all such equipment is expressly excluded from this warranty. Because each system that may use the Product is unique, Motorola Solutions disclaims liability for range, coverage, or operation of the system as a whole under this warranty.

II. GENERAL PROVISIONS:

This warranty sets forth the full extent of Motorola Solutions responsibilities regarding the Product. Repair, replacement or refund of the purchase price, at Motorola Solutions option, is the exclusive remedy. THIS WARRANTY IS GIVEN IN LIEU OF ALL OTHER EXPRESS WARRANTIES. MOTOROLA SOLUTIONS DISCLAIMS ALL OTHER WARRANTIES OR CONDITIONS, EXPRESS OR IMPLIED, INCLUDING THE IMPLIED WARRANTIES OR CONDITIONS OF MERCHANTABILITY AND FITNESS FOR A PARTICULAR PURPOSE. IN NO EVENT SHALL MOTOROLA SOLUTIONS BE LIABLE FOR DAMAGES IN EXCESS OF THE PURCHASE PRICE OF THE PRODUCT, FOR ANY LOSS OF USE, LOSS OF TIME, INCONVENIENCE, COMMERCIAL LOSS, LOST PROFITS OR SAVINGS OR OTHER INCIDENTAL, SPECIAL, INDIRECT OR CONSEQUENTIAL DAMAGES ARISING OUT OF THE USE OR INABILITY TO USE SUCH PRODUCT, TO THE FULL EXTENT SUCH MAY BE DISCLAIMED BY LAW.

III. HOW TO GET WARRANTY SERVICE:

Purchaser must notify Motorola Solutions representative or call Motorola Solutions Customer Response Center at 1-800-247-2346 within the applicable warranty period for information regarding warranty service.

IV. WHAT THIS WARRANTY DOES NOT COVER:

- A) Defects or damage resulting from use of the Product in other than its normal and customary manner.
- B) Defects or damage from misuse, accident, water, or neglect.
- C) Defects or damage from improper testing, operation, maintenance, installation, alteration, modification, or adjustment.
- D) Breakage or damage to antennas unless caused directly by defects in material workmanship.
- E) A Product subjected to unauthorized Product modifications, disassemblies or repairs (including, without limitation, the addition to the Product of non-Motorola Solutions supplied equipment) which adversely affect performance of the Product or interfere with Motorola Solutions normal warranty inspection and testing of the Product to verify any warranty claim.
- F) Product that has had the serial number removed or made illegible.
- G) Batteries (they carry their own separate limited warranty).
- H) Freight costs to the repair depot.
- I) A Product which, due to illegal or unauthorized alteration of the software/firmware in the Product, does not function in accordance with Motorola Solutions published specifications or with the FCC type acceptance labeling in effect for the Product at the time the Product was initially distributed from Motorola Solutions.
- J) Scratches or other cosmetic damage to Product surfaces that does not affect the operation of the Product.
- K) That the software in the Product will meet the purchaser's requirements or that the operation of the software will be uninterrupted or error-free.
- L) Normal and customary wear and tear.
- M) Non-Motorola Solutions manufactured equipment unless bearing a Motorola Solutions Part Number in the form of an alphanumeric number (i.e., TDE6030B).
- N) Lift trucks if required for installation, removal, replacement or repair of the Motorola Solutions-supplied products.
- O) Dispatch to remote site locations.
- P) Loading of software upgrades or fixes into the devices.

V. GOVERNING LAW

In the case of a Product sold in the United States and Canada, this Warranty is governed by the laws of the State of Illinois and the Province of Ontario, respectively.

VI. PATENT AND SOFTWARE PROVISIONS:

Motorola Solutions will defend, at its own expense, any suit brought against the end user purchaser to the extent that it is based on a claim that the Product or its parts infringe a United States patent, and Motorola Solutions will pay those costs and damages finally awarded against the end user purchaser in any such suit which are attributable to any such claim, but such defense and payments are conditioned on the following:

- A) that Motorola Solutions will be notified promptly in writing by such purchaser of any notice of such claim;
- B) that Motorola Solutions will have sole control of the defense of such suit and all negotiations for its settlement or compromise; and
- C) should the Product or its parts become, or in Motorola Solutions opinion be likely to become, the subject of a claim of infringement of a United States patent, that such purchaser will permit Motorola Solutions, at its option and expense, either to procure for such purchaser the right to continue using the Product or its parts or to replace or modify the same so that it becomes non-infringing or to grant such purchaser a credit for the Product or its parts as depreciated and accept its return. The depreciation will be an equal amount per year over the lifetime of the Product or its parts as established by Motorola Solutions.

Motorola Solutions will have no liability with respect to any claim of patent infringement which is based upon the combination of the Product or its parts furnished hereunder with software, apparatus or devices not furnished by Motorola Solutions, nor will Motorola Solutions have any liability for the use of ancillary equipment or software not furnished by Motorola Solutions which is attached to or used in connection with the Product. The foregoing states the entire liability of Motorola Solutions with respect to infringement of patents by the Product or any its parts thereof.

Laws in the United States and other countries preserve for Motorola Solutions certain exclusive rights for copy-

righted Motorola Solutions software such as the exclusive rights to reproduce in copies and distribute copies of such Motorola Solutions software. Motorola Solutions software may be used in only the Product in which the software was originally embodied and such software in such Product may not be replaced, copied, distributed, modified in any way, or used to produce any derivative thereof. No other use including, without limitation, alteration, modification, reproduction, distribution, or reverse engineering of such Motorola Solutions software or exercise of rights in such Motorola Solutions software is permitted. No license is granted by implication, estoppel or otherwise under Motorola Solutions patent rights or copyrights.

EPS – 48759 – O

Post-warranty Service

Repair Service Advantage (RSA) programs are available at additional cost, with options of 1-year RSA (covering year 4) and 2-year RSA (covering years 4 and 5). All other warranty terms and conditions remain the same.

FCC INTERFERENCE WARNING

The FCC requires that manuals pertaining to Class A and Class B computing devices must contain warnings about possible interference with local residential radio and TV reception. This warning reads as follows:

NOTE: This equipment has been tested and found to comply with limits for a Class B digital device, pursuant to Part 90 of the FCC Rules. These limits are designed to provide reasonable protection against harmful interference when the equipment is operated in a commercial or residential environment. This equipment generates, uses, and can radiate radio frequency energy and, if not installed and used in accordance with the instruction manual, may cause harmful interference to radio communications.

Trademarks

Trademarks

Motorola Solutions and the Stylized M logo are registered trademarks of Motorola Solutions Inc.

Microsoft, Windows and the Windows logo are registered trademarks of Microsoft Corporation.

The Bluetooth trademarks are owned by their proprietor and used by Motorola Solutions, Inc. under license in the U.S. and other countries.

IBM is a registered trademark of International Business Machines Corp.

Trimble is a registered trademark of Trimble Navigation Limited.

PCTEL is a registered trademark of Mobile Mark Inc.

All other product or service names are the property of their respective owners.

References

You may need to refer to the documents listed below for further information.

Publication Number	Description
6802983C01	Motorola MW810 Mobile Workstation, Product Safety and RF Exposure for mobile workstation with two-way radios installed in vehicles leaflet (multilingual)
6802988C57	Motorola MW810 Mobile Workstation, R2.0, User Guide
6802988C40	Motorola MW810 Mobile Workstation, R2.0, Quick Reference Guide (multilingual)
6802988C41	Motorola MW810 Mobile Workstation, R2.0, Software Development Kit
6802988C42	Motorola MW810 Mobile Workstation, R2.0, Administrator Guide

For the latest version of this guide and other MW810 Mobile Workstation manuals go to: www.motorola.com/enterprisemobility/manuals

Internet Web Sites

Motorola Web site: <http://www.motorola.com/MW810>

Please note that the Web site location references in this manual are subject to change without notice.

Using this Manual

Who Should Use this Manual

This manual is intended for trained service technicians, radio engineers, and technical operation support staff who install the 810 Mobile Workstation (MW810 Model F5218) in a vehicle.

What is in this Manual

This manual describes the tools and equipment, planning requirements, and product inspections necessary for a smooth installation of the MW810.

Notational Conventions

Throughout this publication, you will notice the use of warnings, cautions, and notes. These notations are used to emphasize that safety hazards exist, and care must be taken.

Do not proceed beyond a **WARNING** or **CAUTION** until the indicated conditions are fully understood and met.

Warning



Indicates a potentially hazardous situation which, if not avoided, **COULD** result in death or serious injury.

Caution



Indicates a potentially hazardous situation which, if not avoided, **MAY** result in minor or moderate injury. **CAUTION** may also be used to alert against unsafe practices and property-damage-only accident hazards.

Note



An operational procedure, practice, condition, etc., which it is essential to emphasize.

This page intentionally left blank

Contents

References.....	iv
Internet Web Sites.....	iv
Using this Manual.....	v
Who Should Use this Manual	v
What is in this Manual	v
Notational Conventions	v
Warning.....	v
Caution	v
Note	v
Introduction	1
How to identify the workstation release number	2
Installation.....	4
Unpacking.....	4
Preparing to Install the MW810 Mobile Workstation Inside the Vehicle	4
Tools.....	4
Planning.....	5
MW810 Mobile Workstation Mounting Location	5
Air Bag Considerations	6
Equipment Ventilation.....	10
Drilling Holes	10
Electrical Guidelines	11
Cable Routing	13
12.1" Display.....	14
8.4" Display.....	18
CPU Box.....	27
Keyboard	32

Interfaces to the MW810 Mobile Workstation CPU Box.....	33
Expansion Board Connections	35
Video In Connection.....	36
USB Connections	37
Serial Connections.....	38
eSATA Port.....	38
LAN Connections.....	38
Mic Line In Connection.....	39
Audio Line Out Connection	39
Power (PWR) Connection	39
AUX Port Connection	40
Display 1 and 2 Connections.....	42
Connection of CPU Box Splitter Cable.....	45
Connection of MW810 Mobile Workstation Auxiliary Port to Vehicle Wiring....	47
Connection of ALPR Cameras.....	48
Turning On the MW810 Mobile Workstation	50
Turn-on Modes.....	50
Turning Off the MW810 Mobile Workstation	51
Storage	52
Appendix A	
Installation, Configuration and Calibration	
of GPS Dead Reckoning	53
Installing the GPS Gyro.....	53
Vertical Installation - front panel facing up	54
Vertical Installation - back panel facing up.....	55
Vertical Installation - CPU back panel facing sideways	56
Horizontal Installation of CPU Box (Default Configuration).....	57
Unsupported CPU Box positions.....	58
Vehicle wire connections	59
U-Blox U-Center Configuration	60
Automatic Calibration.....	64
Basics.....	64
Automatic Calibration – Testing Environment	65
Appendix B -Accessories	67
Acronyms.....	71

Introduction

The Motorola Solutions MW810 Mobile Workstation series is Motorola Solutions highest-performing and most rugged data communication and computing solution. It is specifically designed for the harsh conditions of the mobile environment which is unsuitable for conventional laptop or desktop computers.

The MW810 Mobile Workstation consists of three separate interconnected components: CPU Box, Display, and Keyboard. The system can be mounted in dual airbag-equipped vehicles with proper equipment and mount selections. Using custom-designed cable adapters, the CPU can be connected to a 12.1" or 8.4" MW810 Mobile Workstation display or 3rd-party display with DVI/RGB interface. Each component can also be used as a stand-alone product interfacing to 3rd party equipment.

The MW810 Mobile Workstation is a multipurpose mobile data computer. A single Operating System (OS) can simultaneously support the operation of two independent users (with independent hardware cursor control), each using different display (RGB or DVI) and keyboard. A basic model is available without an expansion option, support a single analog (RGB) or digital (DVI) display.

The MW810 Mobile Workstation design provides a superior computing and broadband communications solution for mission-critical vehicles:

- Versatile Three-Piece Design.
- Third Generation Intel Core i Series CPU platform.
- Mobile radio connectivity and computing power for vehicle users.
- Flexibility and ease of installation in space-limited vehicles. Mechanical connections to Fixed-Mount System for Vehicles.
- Sealed housing.
- Protection against extreme temperatures: automatic heating of hard drive disk when temperature drops below 41°F (5°C).
- Protection against extreme shock and vibration for confidence in mobile environments and under stressful conditions.
- Withstands vehicle cranking conditions.
- Removable Hard Disk Drive (HDD) or Solid State Disk (SSD).
- Easy access to Express Card and Subscriber Identity Module (SIM) cards.
- Internal GPS module options (including dead reckoning) work with user applications to provide accurate vehicle location to manage fleet and deploy resources more effectively.
- Optimized for Wireless including internal wireless wide area network (WWAN), wireless local area network (WLAN), Bluetooth (BT), and Global Positioning System (GPS) options.
- Expanded wireless networking capabilities, including internal cellular modem options, for better access to information.

- Display units with high contrast and backlight offer outstanding performance even in the most difficult lighting conditions. Display design enables shortcuts to the most important user functions.
- Connection to an Automatic License Plate Recognition (ALPR) system (option).
The ALPR system captures an image of license plates, processes it and compares the plate number against data base or hot list.
Each of the four optional ALPR camera housings integrate an infrared and color cameras.
For more information on the ALPR system, refer to PIPS Technology at: <http://www.pipstechnology.com/>.

How to identify the workstation release number

This manual relates to MW810 Mobile Workstation Release 2.0. The release number reflects the type of hardware and software installed inside the MW810 Mobile Workstation.

When receiving the MW810 Mobile Workstation, the release information is included with the documentation attached to the shipping package.

To identify the release number after

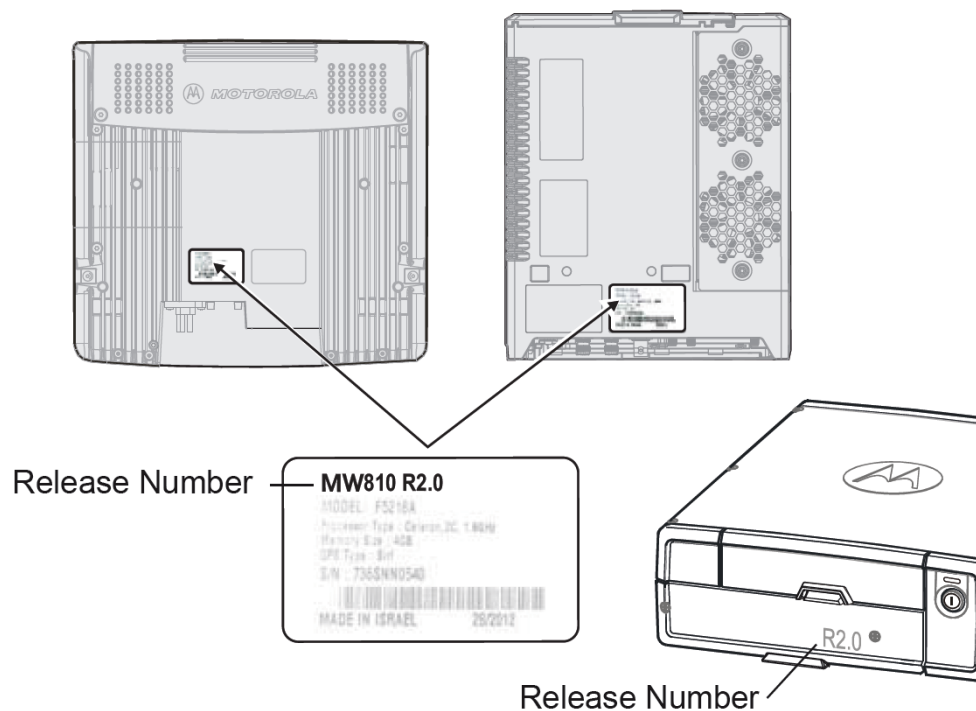

Figure 1
Release Number on MW810 Mobile Workstation Units

Click **Start In** and in the search box enter msinfo32. Your workstation's CPU type will appear in the processor description.

The following CPU types should be displayed:

- Intel® Core™ i7-3610QE 2.3 GHz Quad core processor
- Intel® Core™ i5-3610ME 2.7 GHz Dual core processor
- Intel® Core™ B810 1.6 GHz Celeron processor

Installation

This section describes the tools and equipment, planning requirements, and product inspections necessary for a smooth installation of the MW810 Mobile Workstation. Proper planning will help to ensure that the installation is completed without difficulty and that no damage occurs to the units or the vehicle.



Note

The MW810 Mobile Workstation is a reliable product when installed correctly. However, performance can be seriously impaired if it is not installed correctly. Thoughtful planning can make the difference.



Warning

Please note that installing any part of the MW810 Mobile Workstation must be according to the instructions provided in this manual.

Unpacking

Unpack your shipment and check the contents to ensure that you have received all the specified items.

Thoroughly inspect the equipment for shipping damage as soon as possible after delivery. Report any damage you find to your Motorola Solutions Customer Service representative immediately.

Save the packing carton and anti-static plastic bags for storage and shipping. Both the shipping carton and the anti-static bags protect the MW810 Mobile Workstation components from physical and electrostatic damage.

The following optional parts can be used to mount the MW810 Mobile Workstation:

- Display mount assembly - see “12.1” Display” on page 14 and “8.4” Display” on page 18.
- CPU Box Mounting Trunnion for the MW810 Mobile Workstation CPU - See “CPU Box Mounting Trunnion” on page 31.
- 3rd Party Mounts - <http://www.havis.com/>, <http://www.gamberjohnson.com/>, www.rammount.com/, www.precisionmounts.com/

Preparing to Install the MW810 Mobile Workstation Inside the Vehicle

Tools

The following tools and service aids are required for installation:

- 3/8” nut driver
- 1/2”, 3/8” or 7/16” wrench
- No. 2 and 4 Phillips screwdriver
- Drill with 3/16” drill bit

Planning

Be sure to consider the following issues when planning the installation:

- Keyboard and display location relative to air bag deployment zones
- Environmental considerations
- Electrical guidelines
- Liquid Propane (LP) gas warning
- Usability by driver/operator
- Vehicle vendor instructions
- Local vehicle authority regulations/design rules



When installing the MW810 Mobile Workstation, make sure that the CPU Box Mounting Trunnion or any support is tightly anchored to the vehicle structure. Wobbly Mounting Trunnion can damage the workstation.

MW810 Mobile Workstation Mounting Location

The MW810 Mobile Workstation is typically installed on a Mounting Trunnion assembly, which affixes directly to the vehicle transmission hump or to the tunnel plate (preferred and not included in the kit).

Using an optional tall pedestal under the MW810 Mobile Workstation is recommended only for use in vehicles where air bag compliance is not required. An example of this is a utility van which does not have passenger-side air bags for the given model year.



To avoid radio Interference, the distance between the display and CPU Box mounting locations must be more than 8 inches (20 cm).

Correct positioning of the components will ensure that the MW810 Mobile Workstation meets the following requirements:

- The display and keyboard are within easy reach of the driver/operator (more difficult due to air bag constraints).
- It will not injure the operator or passenger in case of an accident.
- The display does not interfere with the driver's vision.
- The display and the CPU Box are properly ventilated.
- Place the CPU Box so that it can be easily removed for servicing.
- Do not mount the MW810 Mobile Workstation and route its cables where they can be damaged, kicked by the driver's or other passenger's foot.
- Verify that the MW810 Mobile Workstation will not interfere with operation of the vehicle and will not hinder the driver when driving the vehicle.
- Verify that the mounting surface is able to support the weight of the display and the CPU Box.

- To cool the MW810 Mobile Workstation, allow sufficient space around the CPU Box for free air flow.
- Select a location for the CPU Box that permits routing the RF antenna cable as directly as possible.
- If you are mounting the display on a plastic dashboard, you must first reinforce the dashboard; otherwise the weight of the display may crack or break the dashboard.
- Do not mount the CPU Box on a flat or concave surface where the unit could become partially submersed in water.

Air Bag Considerations

When planning the installation of communication equipment in a vehicle with one or more air bags, proceed as follows:

- Installation of vehicle equipment should be performed by a professional installer/ technician qualified in the requirements for such installations. An air bag's size, shape and deployment area can vary depending on vehicle make, model and front compartment configuration (e.g., bench seat vs. bucket seats).
- Contact the vehicle manufacturer's corporate headquarters, if necessary, for specific air bag information for the vehicle make, model and front compartment configuration involved in your equipment installation.

Provided for your reference are several air bag deployment zone templates from automobiles used in public safety roles (Figure 2, Figure 3 and Figure 4).



Caution

Vehicles equipped with air bags:

An air bag inflates with great force. DO NOT place objects, including communication equipment, in the area over the air bag or in the air bag deployment area. If the communication equipment is improperly installed and the air bag inflates, this could cause serious injury.

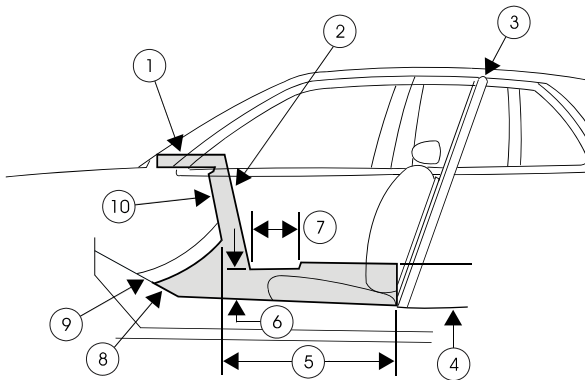

- 1. Area on top of instrument panel
- 2. Area in front of center console from tunnel up to instrument panel
- 3. Prisoner screen
- 4. 254 mm (10 inches)
- 5. Area on tunnel between seats
- 6. Height: 216 mm (8.5 inches)
- 7. 305 mm (12 inches)
- 8. Area on tunnel beneath center console
- 9. Tunnel
- 10. Depth: 38 mm (1.5 inches)

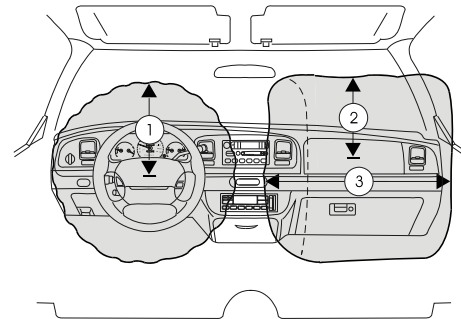

- 1. 240 mm (9.5 inches) from center of air bag door
- 2. 375 mm (15 inches) from center of air bag door
- 3. 750 mm (29.5 inches)

Copyright © 2002 Ford Motor Company

Figure 2
Air Bag Deployment Zones - Crown Victoria

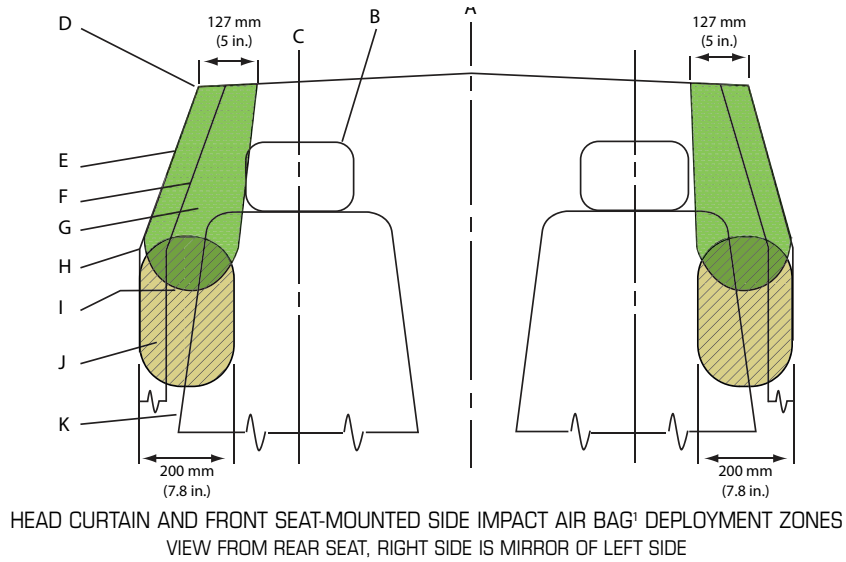

- A. Vehicle center-line
- B. Headrest
- C. Center-line of occupant
- D. Edge of headliner
- E. Door inner trim panel
- F. Center body pillar trim
- G. Head curtain air bag zone
- H. Bottom of door windows
- I. Front door handle
- J. Front seat back thorax air bag zone
- K. Seat back

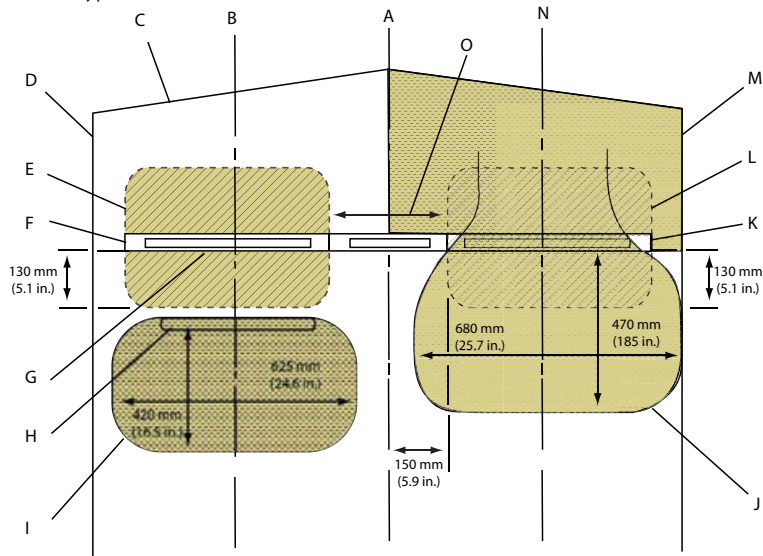

- A. Vehicle center-line
- B. Driver center-line
- C. Front of instrument panel at the windshield base
- D. Driver door trim
- E. Driver knee air bag (model year 2013)
- F. Instrument cluster
- G. Rear-most instrument panel
- H. Steering wheel
- I. Driver air bag
- J. Front passenger air bag
- K. Glove box
- L. Front passenger knee air bag (model year 2013)
- M. Front passenger door trim
- N. Front passenger center-line
- O. Radio stack

1. Head curtain side air bags are designed to help reduce the risk of head and neck injuries to front and rear seat occupants on the near side of certain side-impact collisions. Always use safety belts and the correct child restraints for your child's age and size, even in vehicles equipped with air bags. Children are safer when properly secured in a rear seat. See your vehicle Owner's Manual and child safety seat instructions for more information.

NOTE: All dimensions are approximate and subject to change.

Figure 3
Air Bag Deployment Zones - Chevrolet Caprice

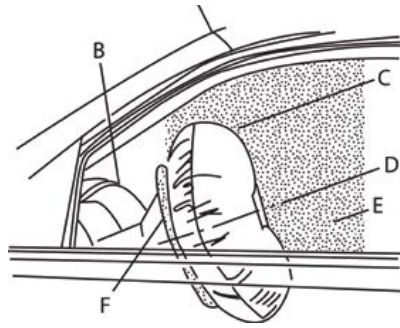

SIDE VIEW OF DRIVER SIDE AIR BAG DEPLOYMENT ZONE

- A. Top edge of windshield
- B. Top of instrument panel
- C. Inflated air bag – steering wheel
- D. Centerline of steering column at mid-tilt
- E. Driver air bag deployment zone
- F. Front of steering wheel

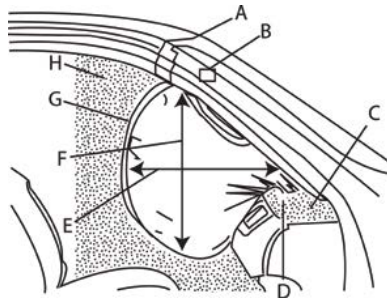

SIDE VIEW OF PASSENGER SIDE AIR BAG DEPLOYMENT ZONE

- A. Top edge of windshield
- B. Inside rearview mirror
- C. Instrument panel top surface zone
- D. Passenger side air bag module trim panel – rear edge
- E. Inflated air bag – horizontal dimension approximate 15.4 in (390 mm)
- F. Inflated air bag – vertical dimension approximate 9.3 in (490 mm)
- G. Inflated air bag – instrument panel
- H. Passenger air bag deployment zone

HEAD CURTAIN AND FRONT SEAT-MOUNTED SIDE IMPACT AIR BAG DEPLOYMENT ZONES VIEW FROM REAR CARGO AREA_e

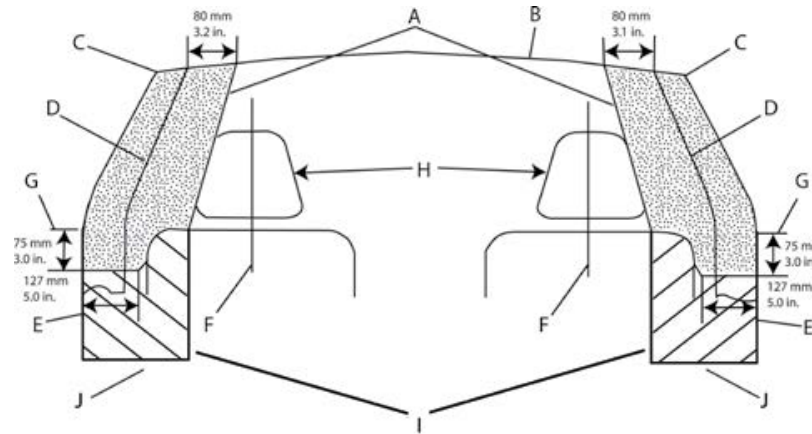

- | | |
|---|---|
| A. Head curtain air bag deployment zone | F. Seat centerline |
| B. Underside of headliner | G. Bottom of door windows |
| C. Edge of headliner | H. Front seat headrests |
| D. Inner center pillar trim | I. Seat-mounted side impact air bags deployment zone front seat |
| E. Inner door pad | J. Top surface of outboard front seat cushion |

Head curtain side air bags are designed to help reduce the risk of head and neck injuries to front and rear seat occupants on the near side of certain side-impact collisions. Always use safety belts and the correct child restraints for your child's age and size, even in vehicles equipped with air bags. Children are safer when properly secured in a rear seat. See your vehicle Owner's Manual and child safety seat instructions for more information.

NOTE: All dimensions are approximate and subject to change.

Copyright © 2012 General Motors

Figure 4
Air Bag Deployment Zones - Chevrolet Tahoe PPV & 5W4

Equipment Ventilation

The display, keyboard and CPU Box are designed to operate properly in an ambient temperature range of -22°F to 158°F (-30°C to +70°C). The MW810 Mobile Workstation CPU must be installed in an area with adequate air flow to allow for proper ventilation.

Installers must install the CPU in an unobstructed location in order to allow proper air flow (see Figure 5). It is imperative to avoid installing the CPU in an enclosure or next to heat generating equipment such as: radio transmitters, power amplifiers or a cabin heater.

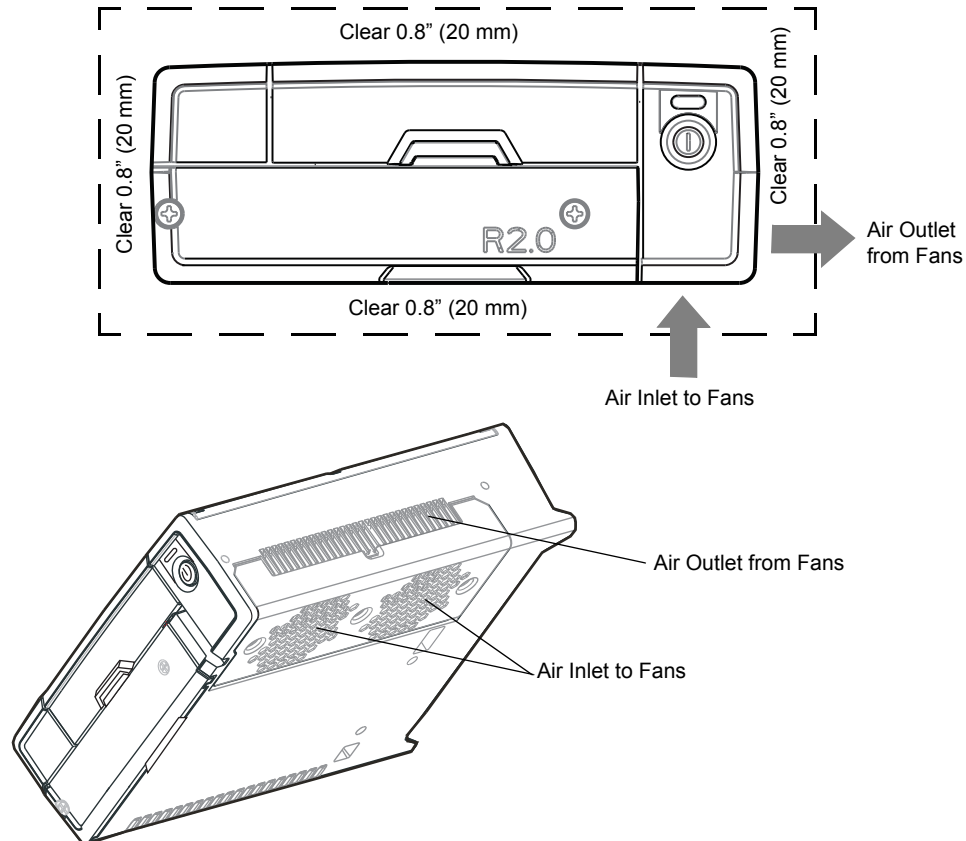

Figure 5
Clear Ventilation Area Around the CPU Box

Drilling Holes

- Where possible, use existing holes in the fire-wall, the trunk wall and the channels above or beneath the doors. Run cables parallel to existing car cables if appropriate.
- When holes must be drilled, verify that other wiring, break lines or gas lines are not damaged.
- When drilling a hole in the roof, take care not to snag the roof liner.
- To prevent rusting after drilling, remove all metal burrs and residue, and completely clean the area to ensure that all steel dust is removed.

- Insert rubber grommets in all drilled holes to protect cables.
- Create permanent driplines (low points) on all cable routes before cables enter roof holes, to help prevent water intrusion.

Electrical Guidelines

The power range requirement for operating the MW810 Mobile Workstation is 13.8 VDC +/- 20% in a 12V battery, 16.5A (maximum) system, negative ground vetting or 27.6 VDC +/- 20% in a 24V battery, 10A (maximum) system, negative ground vetting.

Be sure that the vehicle's electrical system is in good condition. Faults in the alternator and ignition system can be a source of severe Radio Frequency Interference (RFI) and can result in operating problems. Correct any problems in the alternator output, ignition system, and check the battery condition before beginning the installation.



DO NOT install the workstation in a vehicle with a positive-ground electrical system.

The vehicle must have an alternator that can produce a high-current output at low speed (below 18 m.p.h. or 29 km/h) and in an idle state. It also needs the highest rated heavy-duty battery available for the vehicle. The power cables of the MW810 Mobile Workstation should be directly connected to the power system of the vehicle.



Avoid using power Battery Saver relays that cut-off power ruthlessly between the MW810 Mobile Workstation main power and the power system of the vehicle. Uncontrolled power cut-off can damage the MW810 Mobile Workstation operating system, cause loss of data and may require re-imaging of the hard drive. If a power cut-off device is used in order to conserve vehicle battery life, consult a qualified Motorola Solutions authorized installation shop or contact the Motorola Solutions System Support Center for assistance.

Ground Polarity

The MW810 Mobile Workstation should operate only in negative ground electrical systems. Check the ground polarity of the vehicle before starting the MW810 Mobile Workstation installation to verify that the polarity is correct. Accidentally reversing the polarity will not damage the MW810 Mobile Workstation, but will cause the cable fuses to blow.

Due to advanced vehicle assembly techniques, different parts of the vehicle chassis may not be connected to the battery negative terminal. Connecting the ground leads of several devices with a common power supply into different location on the chassis, may cause GROUND potential differences between these locations and damage the MW810 Mobile Workstation or any other installed equipment.

FIRST CHECK that the vehicle chassis point to which you are about to connect the negative lead is properly connected to the battery negative terminal. If the chassis is not properly grounded, connect the negative lead directly to the battery's negative terminal.

When the CPU Box and the display are mounted on a Gamber Johnson mount or next to each other, use a 10AWG ground wire to connect between the body of the CPU Box and the

display. The ground wire ring lugs should be connected, on one side, to one of the screw holes used to secure the CPU Box to the trunnion, and on the other side, to one of the screw holes used to secure the display to a surface.

VERY IMPORTANT: Connect the GROUND lead of any device that is connected to the MW810 Mobile Workstation, i.e., radio or any other equipment, to one common chassis point, via a ring lug, as shown in Figure 6. Please ensure that the chassis point has been cleaned and scraped of any dirt, paint or other material that may prevent a good electrical connection.

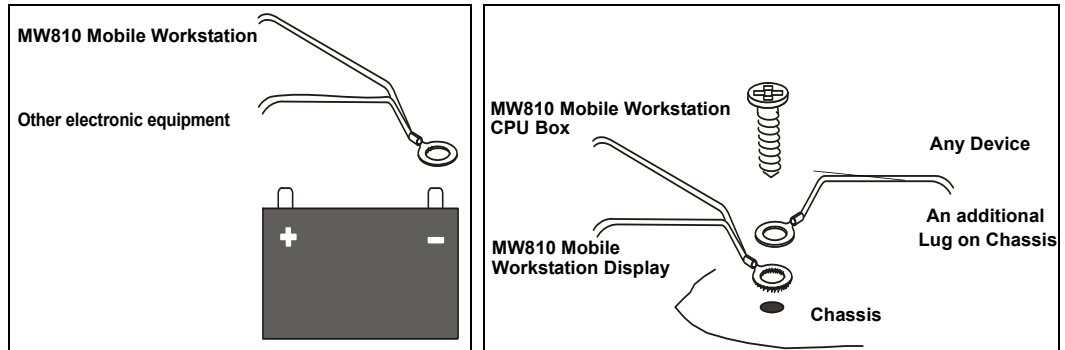

Figure 6
Wire Connection to Battery and Lead Connection to Chassis

If one ring lug cannot hold all the wires, add an additional ring lug and connect it to the battery's negative terminal (-) or to the same chassis point by using the same installation screw. Connect this common lug to the common, grounded chassis point or to the battery's negative terminal (-) as shown in Figure 6. Make sure that all the ring lugs are placed on clean and unpainted surfaces.

Power Cable Installation

1. Determine a routing plan for the power cable, taking into consideration the location at which the unit is to be mounted, and the location of the vehicle battery.
2. In order to pass the power cable through the fire wall and into the engine compartment, locate an existing hole with a grommet in the vehicle fire wall, or drill a 10 mm (0.4 inch) access hole at the desired location. Insert a grommet with a 5 mm (0.2 inch) inner diameter into the access hole to avoid damage to the cable (see Figure 7).

To MW810 Mobile Workstation

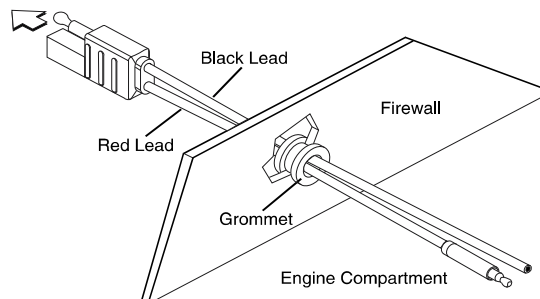

Figure 7.
Cable Routing into Engine Compartment

Take special care not to damage any existing vehicle wires.

3. From inside the vehicle, route the red and black power cable leads (without lugs attached) through the access hole into the vehicle's engine compartment, using accepted industry methods and standards.
4. Locate the nearest available vehicle chassis ground mounting point and shorten the black lead to remove excess cable length.
5. Install the supplied ring lugs onto the stripped end of the black lead, and onto the fuse holder at the end of the red lead (see Figure 8).

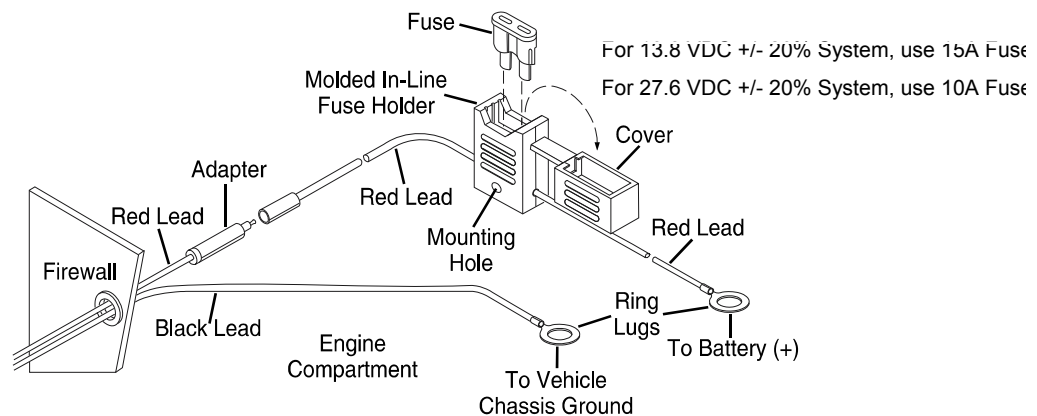

Figure 8
Power Cable Assembly

6. Position the fuse holder as close as possible to the battery, ensuring that it is not close to any hot engine component.
7. Mount the fuse holder, and dress wires as necessary. Connect the red lead plug adaptor (on the fuse holder) to the matching receptacle on the red power cable.
8. Connect the black lead to the vehicle chassis ground. DO NOT connect the black lead directly to the battery's negative (-) terminal.
9. Remove the fuse from the fuse holder and connect the red lead of the power cable to the positive (+) battery terminal. Verify that the adaptor cable is connected to the red lead of the main power cable.
10. Plug the fuse into the fuse holder.



Failure to mount the red lead of the power cable directly to the battery may result in severe alternator whine interference.

Cable Routing

- Before a wire is run or a hole is drilled, inspect the vehicle and determine how and where you intend to mount the antenna, CPU Box and display.
- Plan wire and cable routing to provide maximum protection from overheating, battery acid, moving parts and sharp edges.
- Keep cables away from ignition circuits to reduce noise pickup in the radio equipment.

- Verify that the cables are of sufficient length. Do not connect two short lengths with a connector; doing so will result in signal loss. Refrain from loose excess in the cables, but leave enough slack to allow reconnecting if necessary.
- Do not run cables externally or underneath floor mats.
- Do not locate cables where they can be kicked by the driver or passengers or where they can interfere with operation of the driver's foot pedals.
- When routing the cable, refrain from creating sharp bends or kinks.
- Cables longer than 10 ft. (3.05 m) should be routed through special UL listed conduit/duct for electrical cables. This conduit/duct should fully enclose the cable along its whole length.
- Do not overtighten any tie wraps.

12.1" Display

The 12.1 display is attached to the display mount by Phillips screws (10mm, M4), supplied in the display shipping package. The CPU to Display Signal Cable is routed from the CPU Box, through the mount, and connected to the lower back side of the display (see Figure 9).



Use caution when connecting the display to CPU cable. Rough installation may damage the connectors/receptacles of the display, cable or CPU Box.



Note

To interface the MW810 R2.0, 12.1" Display to a legacy MW810 CPU Box, use CPU Box to Display R2.0 to Display (50 pin to 60 pin) adaptor cable - P.N: FKN00010.

When interfacing the MW810 R2.0, 12.1" Display to a legacy MW810 CPU Box, software installation is also required. (See MW810 Mobile Workstation, R2.0, Administrator Guide P.N 6802988C42.)

Form a service loop for the Power and Display Signal Cables to reduce cable tension. Use plastic cable tie wraps to secure the cables to cable tie points. Do not overtighten the tie wraps.



Note

The Function keys of the display include an illuminated area designed for description labels. Contact your Motorola Solutions representative for assistance ordering custom-made labels as needed.

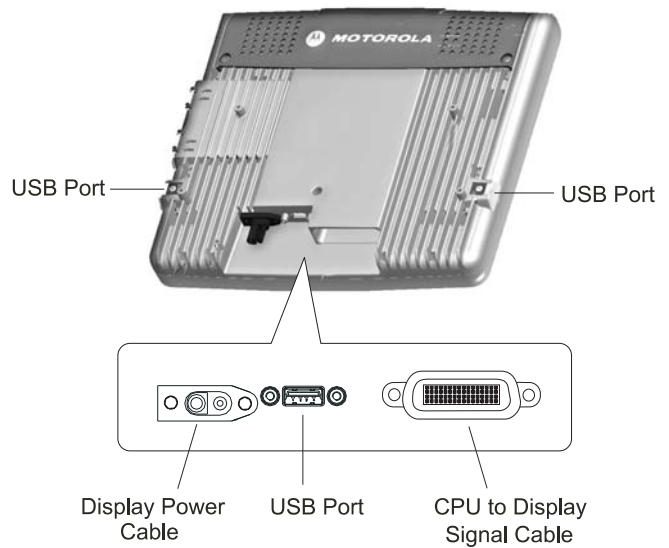
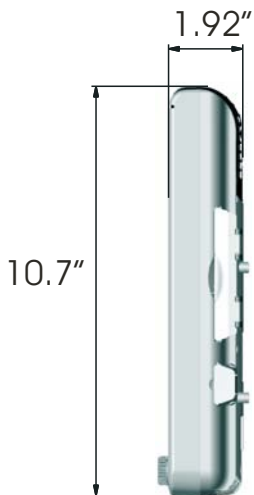
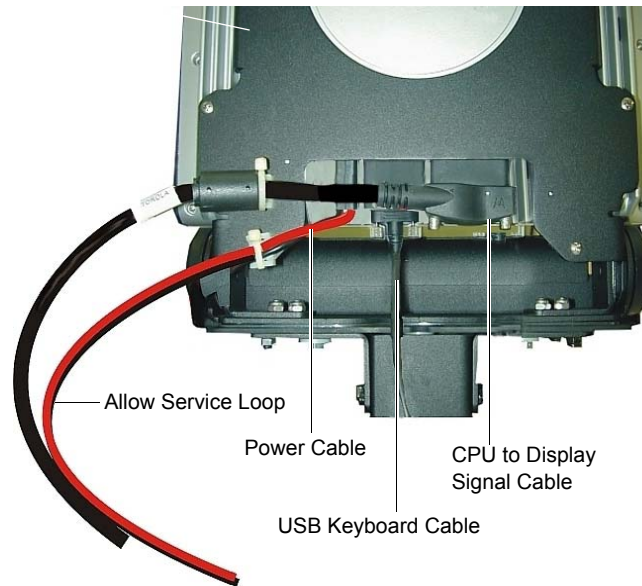
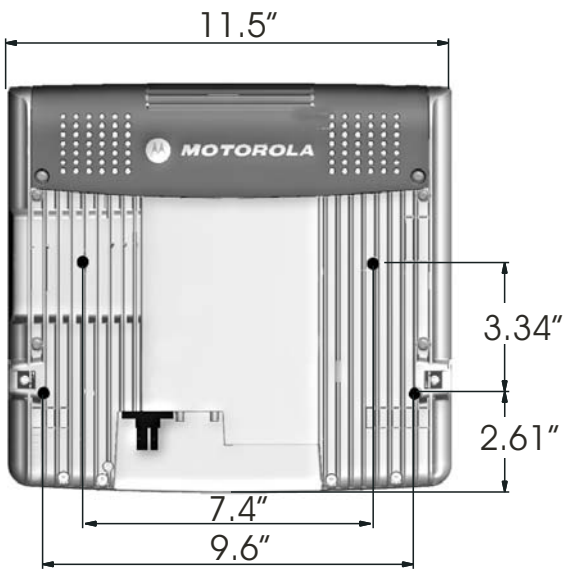

Figure 9
12.1" Display Size and Cable Route on Mount



To comply with safety regulations, the distance between the display mounting location and people sitting inside the vehicle **must** be more than 8 inches (20cm).



- Long Display Signal Cables (longer than 3 Meters, 10 feet) should be routed inside protective ducts to avoid damage.
- The MW810 Mobile Workstation Display is shipped with a protective film that covers the touch screen. Once installation is completed, the protective film must be removed to avoid damage to the touch screen during operation. If any residue from the protective film remains upon removal, use a dry soft cloth and gently rub it off, toward the center of the display so it does not wedge into the bezel of the touchscreen.

Connection to Standard Personal Computer

12.1" Display to DVI (or RGB) Standard CPU Cable enables to interface the MW810, 12.1" Display to any personal computer.

Interfacing the MW810, 12.1" Display to a standard laptop or personal computer with DVI connection requires the following components:

- 12.1" Display to DVI Standard CPU - P.N: FKN8454
- Adaptor Cable - FKN000100

Interfacing the MW810, 12.1" Display to a standard laptop or personal computer with RGB connection requires the following components:

- 12.1" Display to RGB Standard CPU - P.N: FKN84493
- Adaptor Cable - FKN000100

For cable connection, refer to Figure 10.

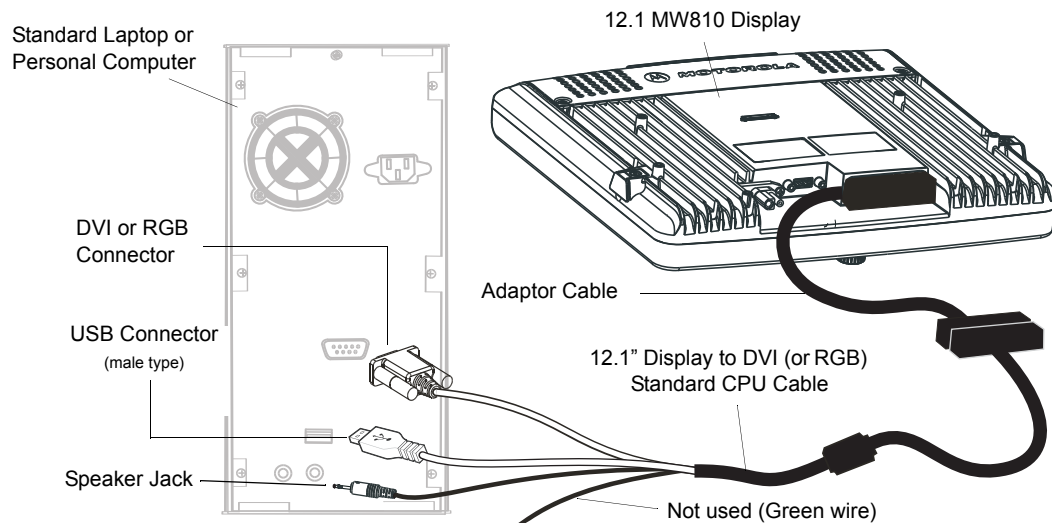

Figure 10
Connection of MW810, 12.1" Display to a Standard Personal Computer

The following table describes the connectors of the MW810, 12.1" Display to Laptop or Standard Personal Computer.

Connector	Description
RGB or DVI	RGB or DVI signals from the personal computer to display.
USB 2.0	USB communication with the personal computer. This communication enables operation of the function buttons, emergency button and Power button for turning the workstation On/Off.
Speaker Jack	Audio signal from the personal computer to display speaker.

8.4" Display

The 8.4" Display can be attached to a mount by four 10mm, M4 screws.

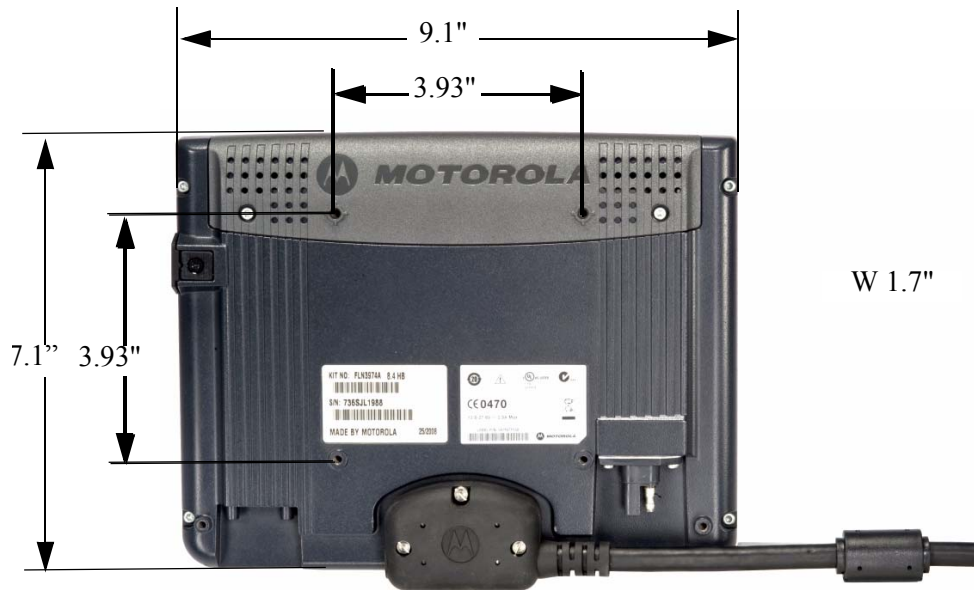

Figure 11
8.4" Display Size



Note

The CPU box to Display cable can be ordered in two basic configurations with various lengths:

- 1) Right side driving countries (driver's seat on left-hand side). Seen from the front, cable exits to the right away from the driver (see Figure 11).
- 2) Left side driving countries (driver's seat on right-hand side). Seen from the front, cable exits to the left, away from the driver.

When



Note

To interface the MW810, 8.4" display to a MW810 CPU Box R2.0, use CPU Box R2.0 to Display (60 pin to 50 pin) adaptor cable P.N: FKN0003. When

When interfacing the MW810, 8.4" display to a MW810 CPU Box R2.0, software installation is also required. (See MW810 Mobile Workstation, R2.0, Administrator Guide P.N 6802988C42.)



Note

The Function keys of the display include an illuminated area designed for description labels. Contact your Motorola Solutions representative for assistance ordering custom-made labels as needed.

This page intentionally left blank

The 8.4" Display supports the following installation methods:

- Free-standing Pedestal Mount
- In-dash DIN Mount

The Free-standing Pedestal Mount

The Free-standing Pedestal Mount affixes to the vehicle's floor or transmission hump using self tapping screws or bolts. It allows the display mount to be readjusted to either the driver or passenger side for most comfortable viewing angle. A single adjustment knob enables adjustment of both upper and lower ball joints simultaneously.

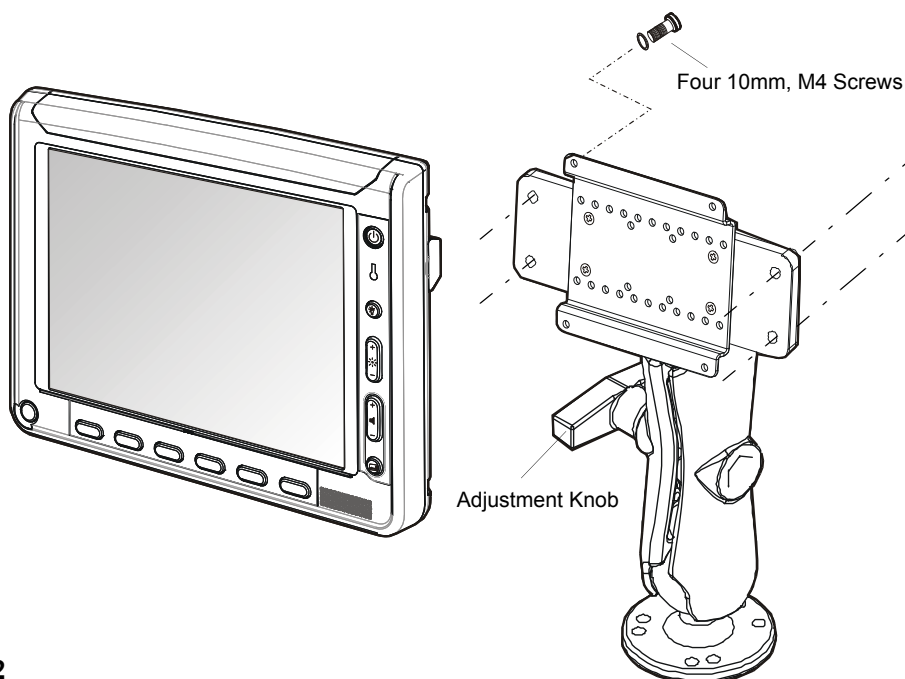

Figure 12
MW810 8.4" Display - Free-standing Pedestal Mount

This section describes the tools and equipment, planning requirements, and product inspections necessary for a smooth installation of the 8.4" Display.

Proper planning will help to ensure that the installation is completed without difficulty and that no damage occurs to the units or the vehicle.



The 8.4" Display is a reliable product when installed correctly. However, performance can be seriously impaired if it is not installed correctly. Thoughtful planning can make the difference.



Installing any part of the 8.4" display must be according to the instructions provided in this manual.

To install the Free-standing Pedestal Mount, perform the following steps (see Figure 13):

Step 1. Select the location to achieve optimal functionality and use of the 8.4" Display.

Step 2. If screws and nuts are used for anchoring the mount, mark the hole locations using the base of the mount and drill four 5.5 mm holes into the dashboard.

Step 3. If self-tapping screws are used for anchoring the mount, attach the mount to the desired location and drive the screws into the dashboard.



Be careful not to drill or drive screws into wires, circuits or equipment located under the dashboard

Step 4. Connect the display to the VESA Plate and secure using four screws and washers.



Note

The pedestal mount can be assembled to the VESA plate on both of it's base end sides.



Note

It is very important to use spring washers when securing the display to the Display Bracket.

Step 5. Connect the display signal cable and the power cable to the display.

Step 6. Using four screws, install the display to the pedestal Mount.

Step 7. Adjust the display position.

Step 8. Route the Display Signal and Power cables down to the CPU Box. Ensure that the cables have enough slack to move when the display is tilted up/down or swiveled.

For cable connections, refer to steps 5 to 7 of "To assemble and install the Display DIN Mount, perform the following steps (see Figure 16):" on page 24.

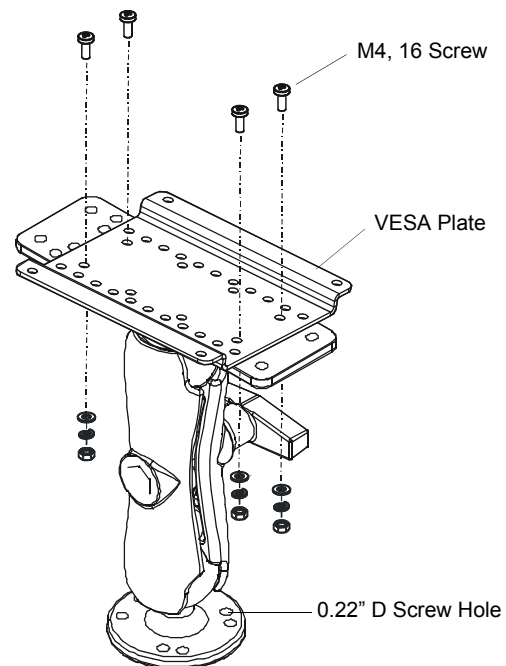

Figure 13
8.4" Display - Free-standing pedestal mount

In-dash DIN Mount

The In-dash DIN Mount is a rectangular (2" high x 7" wide) mount that can be adapted to most vehicles produced today that contain a standard 'Single DIN' opening.

During installation, the display can be adjusted to provide optimal accessibility using the following pivot and mounting adjustments (see Figure 14):

- Swivel: up to 13°
- Tilt: up to 35°
- Vertical: up to 70 mm
- Horizontal: up to 30 mm
- Extension out: up to 48 mm

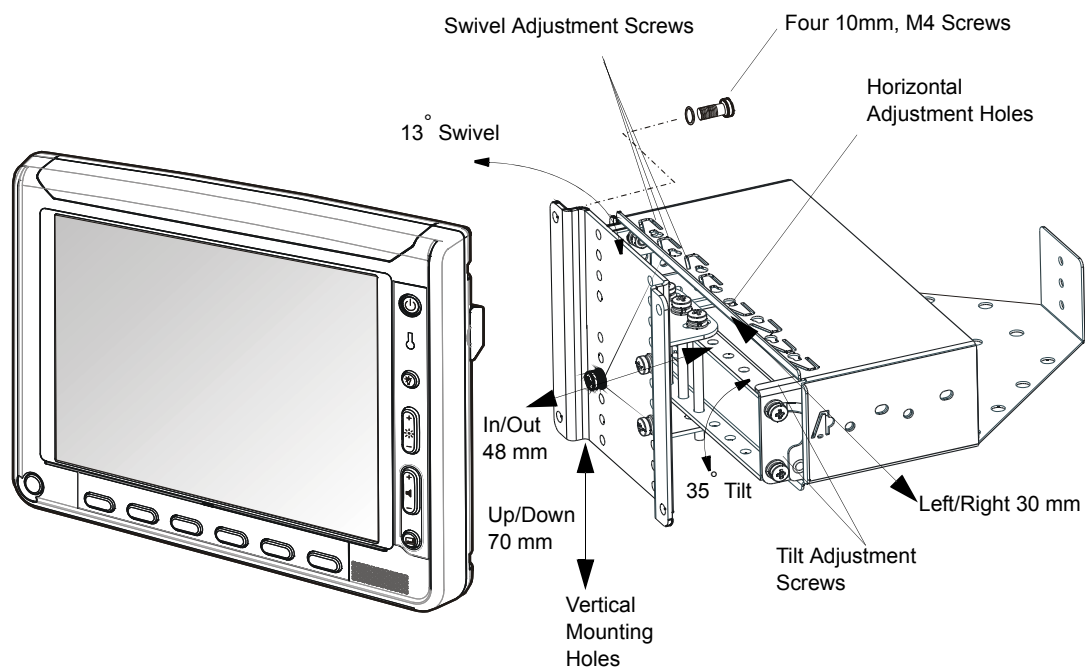

Figure 14
8.4" Display - In-dash DIN Mount



Note

The In-dash DIN Mount has no parts that can be adjusted by the user. Mount readjustment can only be performed by service technicians.

To mount the DIN sleeve inside the radio slot, perform the following steps:



The DIN mount can only be adjusted during installation and may require reinstallation before the final position is determined. No end-user adjustment is available.

Note

The following installation steps may change according to your specific vehicle model and application requirements.

- Step 1. Remove the radio (if exists) from radio slot in the vehicles dash.
- Step 2. Route the display signal cable and the power cable through the radio slot in the vehicles dash.
- Step 3. Slide the DIN sleeve into the slot in the vehicle dash and route the display signal cable and the power cable through the sleeve.
- Step 4. When the sleeve is fully inserted and the front edge or lip is seated, secure the sleeve to the radio slot by bending the tabs on the sleeve behind the plastic of the dash.

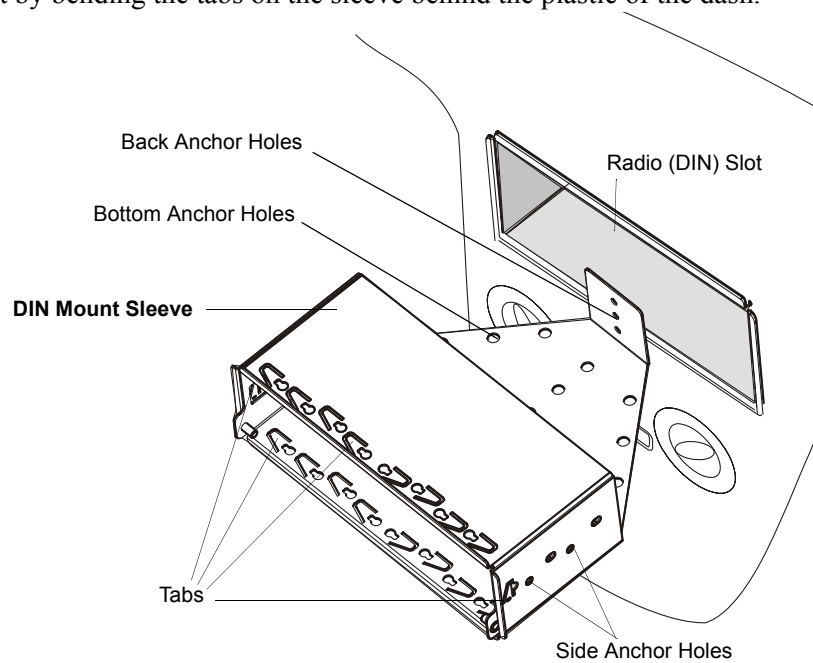

Figure 15
8.4" Display - Installation of DIN Sleeve



Warning

To ensure maximum safety, the DIN sleeve **must** be fastened to the vehicle using the back, and/or side and bottom anchor holes.

To assemble and install the Display DIN Mount, perform the following steps (see Figure 16):

- Step 1. Position the left-hand side and right-hand side Arm Brackets inside the DIN Sleeve. Use the holds on the arms to determine the distance of the display from the dash, and fasten the arms using four nuts to inner studs.

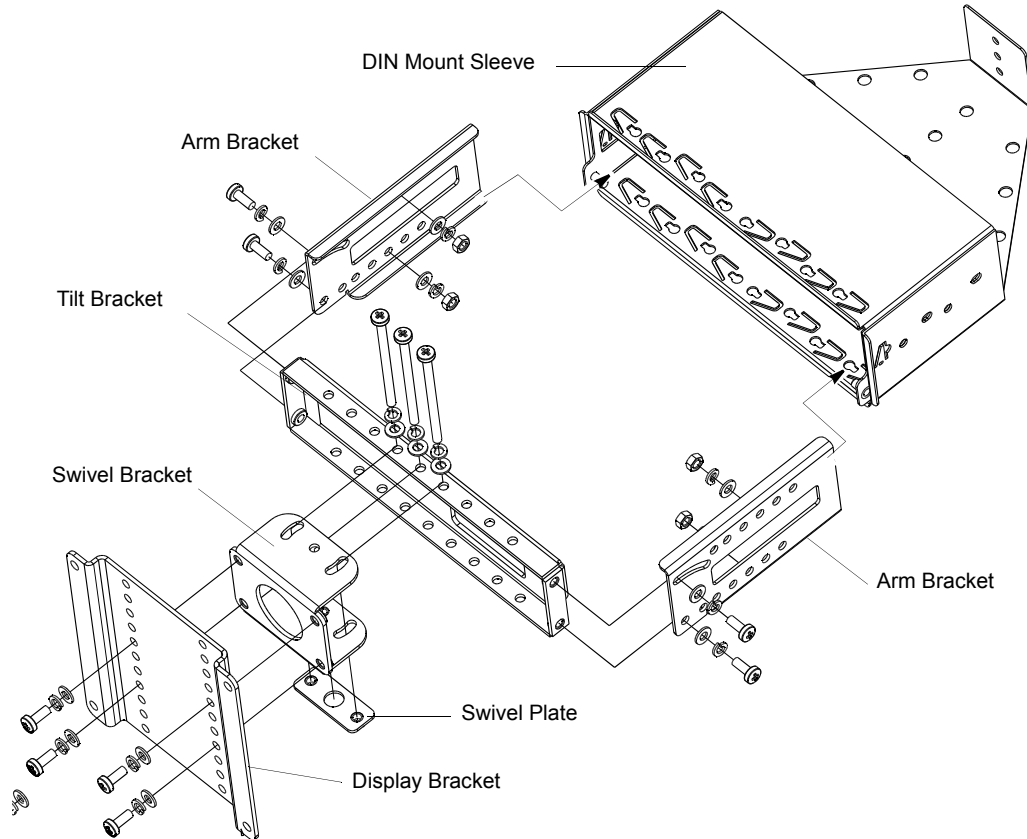

Figure 16
8.4" Display - DIN Mount Breakdown



Note

Vehicle vibrations may loosen the mount parts. It is very important to use the spring washers when assembling the display mount.

- Step 2. Use four screws to connect the left-hand side and right-hand side Arm Brackets to the Tilt Bracket. Pivot the Tilt Bracket up/down to determine the display tilt position and secure the four screws.
- Step 3. Route the display signal cable and the power cable through the opening in the Tilt Bracket.
- Step 4. Use four screws to connect the Swivel Bracket to the Display Bracket. Use the line of holes on the Display Bracket enable to determine the display height position and connect the display using four screws.

Step 5. Plug the connector of the display signal cable and use the three screws to secure the connector to the display.

Step 6. Note that cables are available with right-side or left-side display exit for right-side or left-side driver seat position.



Use caution when connecting the display to CPU cable. Rough installation may damage the connectors/receptacles of the display, cable or CPU Box.



To avoid damage to the display and CPU Box, verify that the Main Power switch, located on the back panel of the CPU Box, is turned Off before connecting cables to the display.

Step 7. Plug the keyboard cable to the USB port and secure the cable to the display by using the thumb screws.



Note

The maximum current load from USB 2.0 port is 500mA.

Use the rubber plug, provided with this product, to seal the port when not in use.

Step 8. Plug the power cable to the power connector on the back of the display.

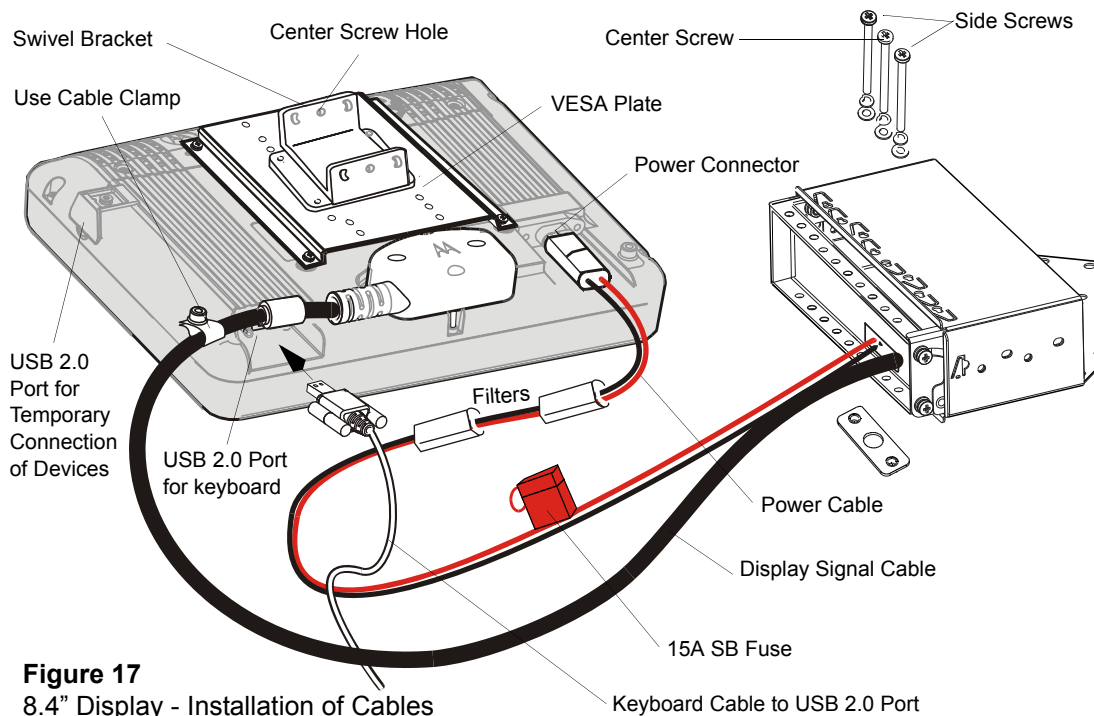

Figure 17
8.4" Display - Installation of Cables



Note

The display is powered directly from the vehicle power system. The display software uses power management tools to prevent excessive battery drainage during normal operation and vehicle start.

Step 9. Assemble the Swivel Bracket (connected to the VESA plate) to the Tilt Bracket. The Swivel Bracket determines the pivot position of the display.

Step 10. Use the center screw slot on the Swivel Bracket to align the display and set the swivel angle, then fasten using the two side screws and Swivel Plate.

Connection to Standard Personal Computer

The Laptop to MW810, 8.4” Display Signal Cable (optional DVI, P.N: FKN8547 or RGB, P.N: FKN8546 cable) enables you to interface the MW810, 8.4” Display to any laptop or personal computer. For cable connection, refer to Figure 18.

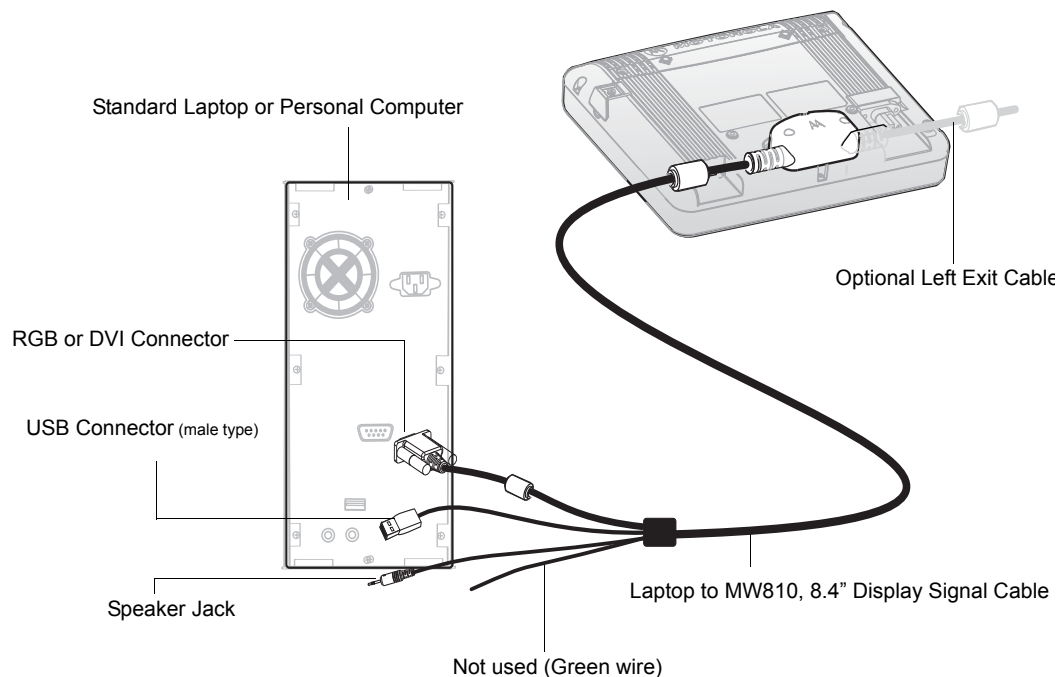

Figure 18
Connection of MW810, 8.4” Display to Laptop or Standard Personal Computer

The following table describes the connectors of the MW810, 8.4” Display to Laptop or Standard Personal Computer.

Connector	Description
RGB or DVI	RGB or DVI signals from the personal computer to display.
USB 2.0	USB communication with the personal computer. This communication enables operation of the function buttons, emergency button and Power button for turning the workstation On/Off.
Speaker Jack	Audio signal from the personal computer to display speaker.

CPU Box

The MW810 Mobile Workstation CPU Box should be mounted so that cables coming from the keyboard(s), display(s), power system and peripherals can be attached easily to the connector panel. The maximum length of the display signal cable is 5 meter (16.4 feet). Whenever one of the MW810 Mobile Workstation receptacles is not in use, it is recommended to leave the receptacle plug. Use the supplied rubber plugs to cover the unused receptacles (see Figure 19).

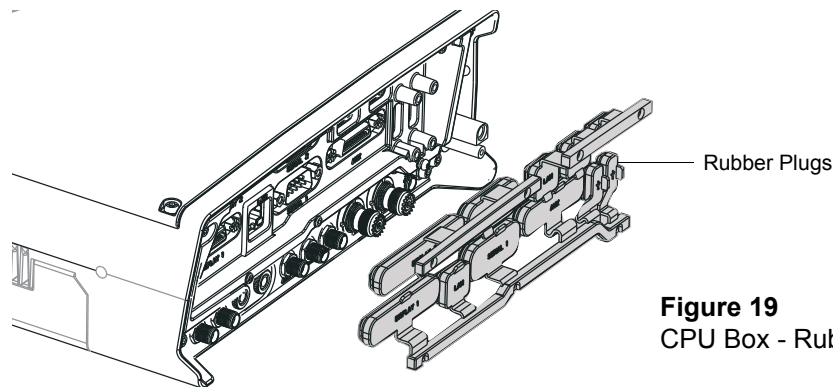

Figure 19
CPU Box - Rubber Plugs

Express Card Slot

The Express Card Slot is used for memory storage express card size 34mm or 54mm. The card is installed inside the CPU Box in the Express Card Slot (see Figure 20).

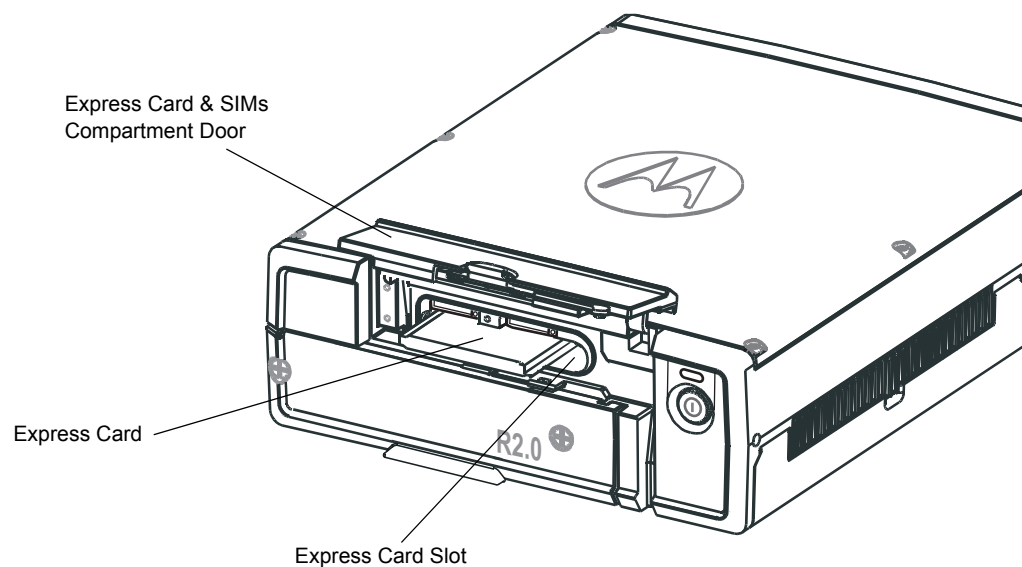

Figure 20
CPU Box - Express Card Installed in the Express Card & SIMs Compartment

SIM Card Installation

The MW810 Mobile Workstation requires a SIM card to activate the WWAN radio. The SIM card fits inside the Express Card & SIMs Compartment. The SIM card holds the MW810 Mobile Workstation identification information required for connecting to a cellular network.

To install a SIM card for the first time, perform the following steps:



Before installing the SIM card, verify that MW810 Mobile Workstation is turned off. Inserting or removing the SIM card when MW810 Mobile Workstation is running can corrupt the SIM card information.

- Step 1. Open the Express Card & SIMs Compartment Door.
- Step 2. Retrieve the SIM Card Drawers from a red plastic bag inside the CPU Box package.
- Step 3. Install the two SIM Card Drawers inside the Express Card & SIMs Compartment. Verify that the left drawer indicates SIM1 and the right drawer indicates SIM2. Slide-in the drawers and verify that they are locked in place.
- Step 4. Press the Eject Button of SIM1 Card Drawer (for WWAN1 radio) and slide-out the SIM Card Drawer.
- Step 5. Place the SIM Card inside the SIM1 Card Drawer. Make sure that the gold plate of the SIM card is facing up and the notch of the SIM card fits in the proper direction inside the SIM1 Card Drawer.
- Step 6. Slide-in to lock the SIM1 Card Drawer.
- Step 7. Close the Express Card & SIMs Compartment Door.

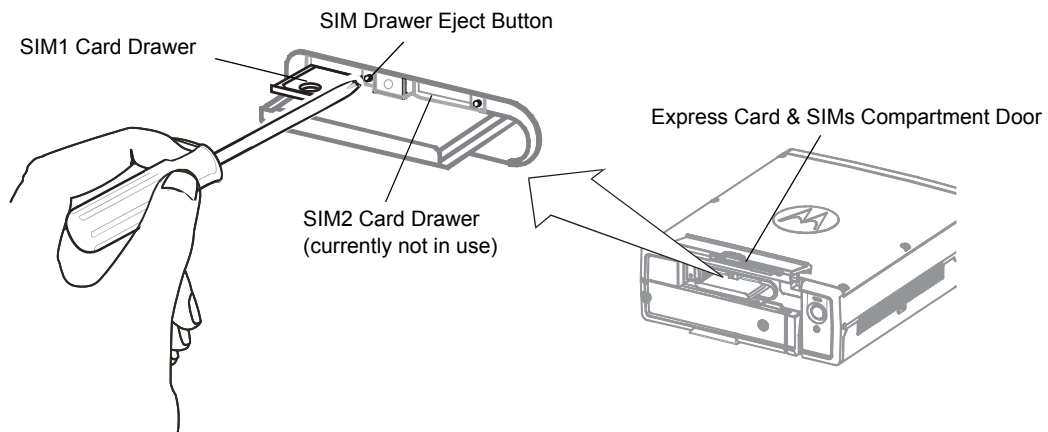

Figure 21
CPU Box - SIM Cards Installation

Hard Disk Drive/Solid State Disk Compartment

The CPU Box is supplied with a removable Hard Disk Drive (HDD) or Solid State Disk (SSD) that interfaces to the CPU Box enclosure via a SATA3 connector.

R2.0 CPU Boxes do not support legacy R1.X HDD or SSD enclosures. Legacy R1.X HDD or SSD enclosures are not interchangeable with R2.0 enclosures. To identify R2.0 HDD or SSD, look for the R2.0 mark on the front panel of the enclosure.

The HDD is equipped with a built-in heater that automatically turns on at low temperatures. When the temperature drops below 41°F (5°C), a built-in heater starts operating to maintain the HDD in working conditions. If the HDD temperature is below 41°F (5°C) during boot-up, a message is issued indicating that the heater is starting to operate and slightly delaying start-up due to time-out of HDD heater function.



Note

The SSD does not require/include a heater to operate at low temperatures.

To remove the HDD/SSD unit:

- Step 1. Shut down the MW810 Mobile Workstation.
- Step 2. Switch off the On/Off power switch located at the backpanel of the CPU Box (see Figure 3).
- Step 3. Loosen the two screws securing the HDD/SSD Unit to the CPU Box (see Figure 6).
- Step 4. Pull out the HDD/SSD Unit from the HDD/SSD Unit Compartment in the CPU Box.

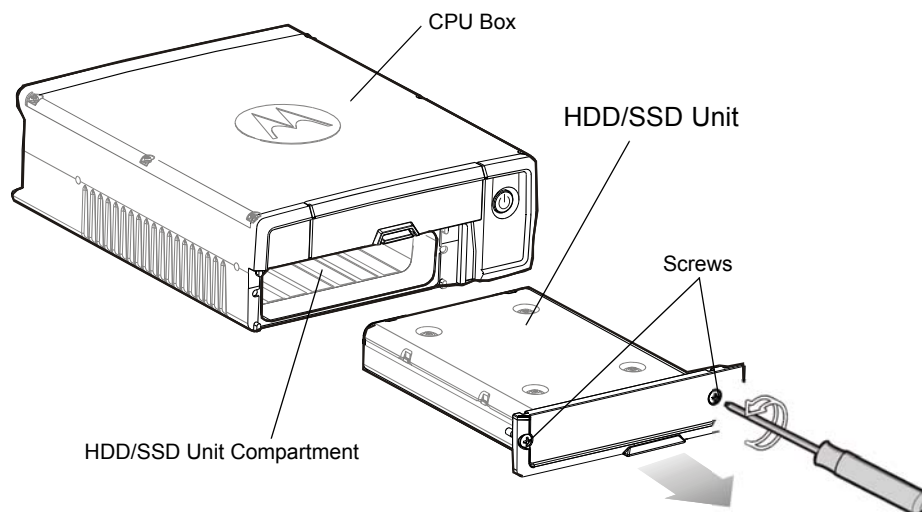

Figure 22
CPU Box - Removal of Hard Disk Drive/Solid State Disk Unit



1. Never try to remove the HDD/SSD unit before shutting down the workstation and switching off the On/Off power switch on the backpanel of the CPU Box. Doing so can result in loss of data, and can damage the workstation and the sensitive circuitry of the HDD.
2. Make regular backups of data from your HDD to an external flash disk or other storage media.
3. Once the HDD/SSD Unit is removed from the HDD/SSD Unit Compartment, the CPU Box is not sealed. In such condition, do not expose the CPU Box or HDD/SSD Unit to sand, dust, liquid or extreme humidity.

The CPU Box Mounting Trunnion

When installing the CPU Box, a Mounting Trunnion (see Figure 23) should always be used unless an alternate method or other mounting option is specifically certified by Motorola Solutions.

The CPU Box can be mounted at any place in the passenger compartment that provides adequate ventilation (see Figure 5).

It is recommended that the CPU Box be mounted in a place where the removable HDD/SSD enclosure, Express Card & SIMs Compartment can be easily accessed. Attach the adhesive tape, provided in the shipping carton, to the Express Card to enable easy removal of the Express Card from the Express Card & SIMs Compartment.

Suggested locations for CPU Box installation, in order of preference, are: on the trunk tray, on the front of the prisoner cage, under the dashboard, inside the console, or under the seat (not in the direct path of the vehicle heater air flow).

The CPU Box Mounting Trunnion is attached to the CPU Box by four bolts supplied with the Mounting Trunnion. The Mounting Trunnion can be affixed to a flat surface by eight bolts (not included).

The CPU Box Mounting Trunnion enables the CPU Box to be mounted on the flat surface or pedestal. It is recommend to install the Mounting Trunnion within +/- 5 degrees of vertical/horizontal planes to in order for the hard drive anti-vibration system to work properly.

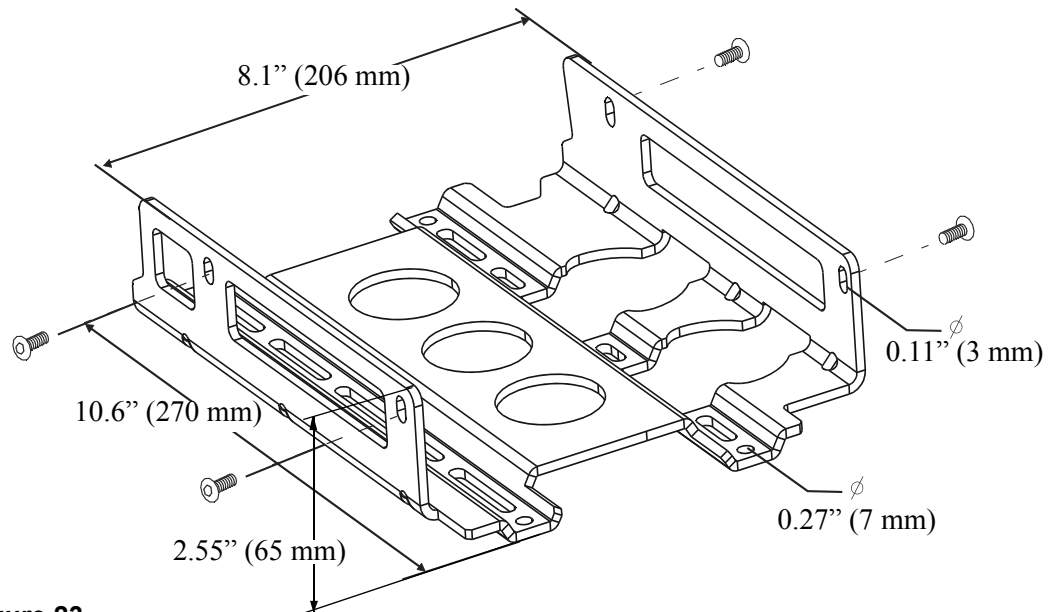
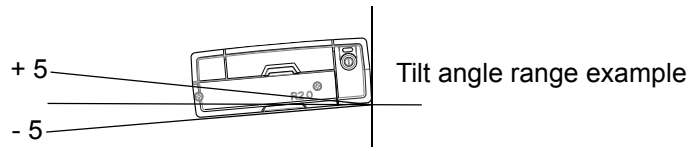

Figure 23
CPU Box Mounting Trunnion



Caution

When installing a CPU Box equipped with a GPS Dead Reckoning gyro, do not exceed + -5 degrees tilt angle **from each vehicle axis**. Installing the CPU Box over + -5 degrees tilt angle from one or more of the vehicle axis may result in gyro reading error while in DR mode.



For GPS Dead Reckoning installation, refer to "Appendix A Installation, Configuration and Calibration of GPS Dead Reckoning" on page 43



Note

Motorola Solutions recommends the use of the CPU Box Mounting Trunnion. Failure to do so may result in hard drive damage due to vibration.

Keyboard

The keyboard tray may be placed anywhere in the vehicle. Please ensure that all safety guidelines and air-bag deployment requirements are met.

When a mounting tray is used, the keyboard is provided with a quick release holder to allow operation of the keyboard when out of the holder. Care must be used to ensure ample space for extracting and reinserting the keyboard into the holder. Ensure that the cable is routed in a manner that allows the operator to remove the keyboard from the mounting tray and operate the keyboard on the lap.

The all Displays have a standard Universal Serial Bus (USB) type A receptacle to which is generally used for QWERTY style keyboard. The maximum current load from USB 2.0 port is 500mA. When a keyboard is used, the keyboard cable connector should be secured to the display by thumb screws.

Use the rubber plugs provided with Display or CPU to seal unused ports.



Warning

All auxiliary devices connected to the display (keyboard or any USB peripherals) must be anchored or secured to the vehicle. Pull off the road and park before using the keyboard, if driving conditions or regulations so require.

Failure to comply with this warning may result in body injury or even death in case of vehicle impact (see example in Figure 24)

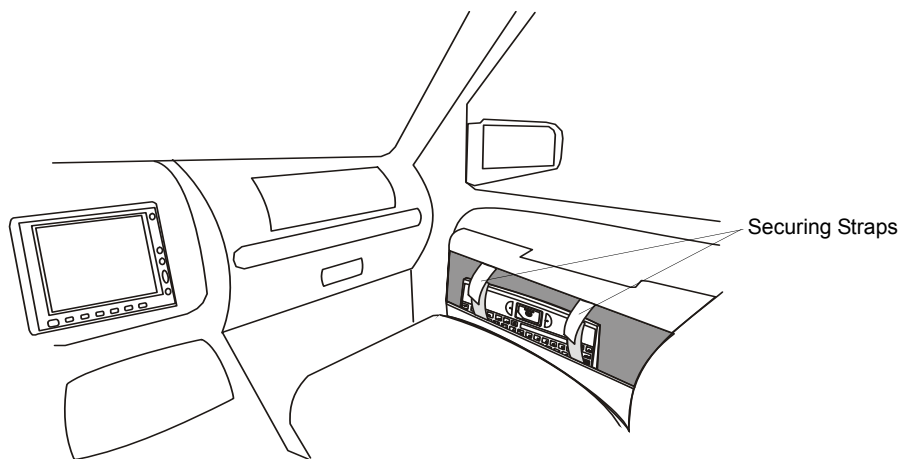

Figure 24
Keyboard Secured in Door Compartment

Interfaces to the MW810 Mobile Workstation CPU Box

With the mechanical installation complete, hook up the optional antennas and other peripheral devices to the CPU Box and Display.

The MW810 Mobile Workstation offers multiple expansion board options, each with a different rear panel, so you can add more ports for external modems, video cameras, or other vehicle peripherals as required.

Figure 25 shows the expansion board options of CPU Box of the MW810.

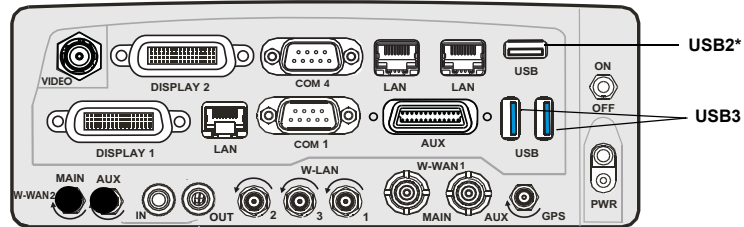

CPU Box - Extra Display, Video & I/O Expansion Board Option

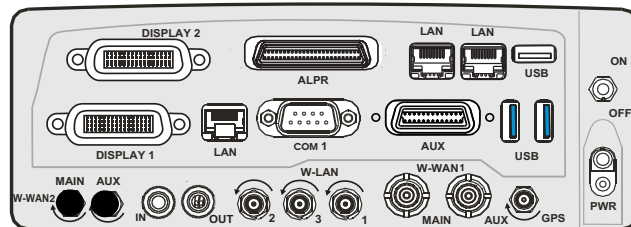

CPU Box - Extra Display & ALPR Expansion Board Option

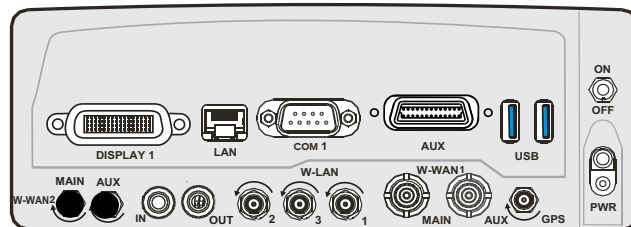

CPU Box - No Expansion Board Option

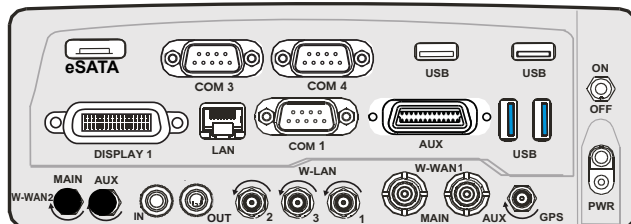

CPU Box - eSATA & I/O Expansion Board Option

* Although this port has USB 3.0-ready hardware (blue connector type), it is currently configured to USB 2.0 in the BIOS implementation.

Figure 25 CPU Box - Expansion Board Options

Figure 26 shows an optional connection layout of the CPU Box with Extra Display, Video & I/O Expansion Board option to peripheral devices, system and power.

Ensure that the cables are properly routed to prevent damage to the cables and any operator hazards. Connect the DC Power cables at the end of the connection process.

Important Note: Use the supplied rubber plugs to cover the unused receptacles.



CAUTION

Do not connect or disconnect any peripheral device during the boot-up process or when the CPU is in power-saving mode.

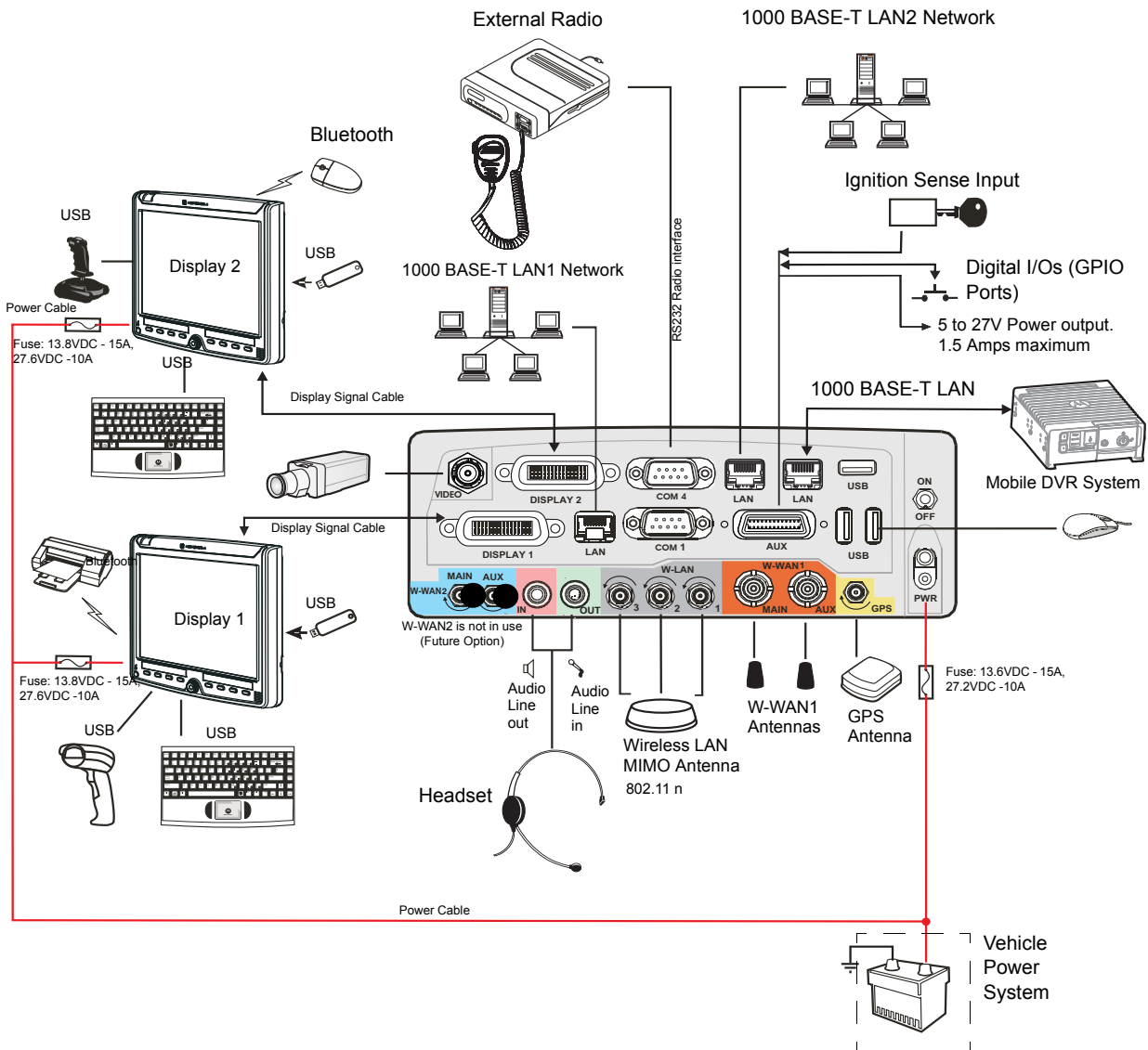

Figure 26
Optional Connection Layout of CPU Box with Extra Display, Video & I/O Expansion Board Option to peripheral devices, system and power.

Expansion Board Connections

Installation Guidelines

Vehicle RF antennas must be installed external to the vehicle and in accordance with:

- The requirements of the antenna manufacturer/supplier.
- Instructions in the installation manual of the external radio (in case an external radio is used).



Warning

To comply with safety regulations, the distance between antennas and people sitting inside the vehicle must be more than 8 inches (20 cm).

When mounting antennas, the distance between the antennas must be more than 8 inches (20 cm).

IMPORTANT NOTE: To assure optimum performance and compliance with RF Energy Safety standards, these antenna installation guidelines and instructions are limited to metal-body vehicles with appropriate ground planes and take into account the potential exposure of back seat passengers and bystanders outside the vehicle.

For detailed product safety and RF exposure, refer to Safety and General Information leaflet, Motorola Solutions publication number 6802983C01.

Selecting an Antenna Site/Location on a Metal Body Vehicle

1. External installation – Check the requirements of the antenna supplier and install the vehicle antenna external to a metal body vehicle in accordance with those requirements.
2. Roof top – For optimum performance and compliance with RF Energy Safety standards, mount the antenna at the center area of the roof.
3. Ensure that the installation surface is grounded by connecting grounding straps between the surface and the vehicle chassis.
4. Ensure that the antenna cable can be easily routed to the MW810 Mobile Workstation. Route the antenna cable as far away as possible from any vehicle electronic units and its associated wiring.
5. Check the antenna location for any electrical interference.



Note

Metal pieces rubbing against each other (such as seat springs, shift levers, trunk and hood lids, exhaust pipes, etc.) in close proximity to the antenna can cause severe receiver interference.

W-WAN1 Antenna Connections

If your MW810 Mobile Workstation includes an internal a Wireless Wide Area Network (WWAN) radio, connect the Mini UHF plug of the antenna RF cable to the MAIN jack of W-WAN1 on the rear panel. For best coverage and communication performance, connect two antennas to W-WAN1 - one to the MAIN and one to the AUX jack. All 4G WWAN radio modules are designed for use with two antennas (use the MAIN and AUX jacks).

To ensure a secure connection of an antenna cable's mini-UHF plug to W-WAN mini-UHF jacks, their interlocking features must be properly engaged. If they are not properly engaged, the plug will come loose. Using a tool (pliers or wrench) will not overcome a poor engagement, and is not recommended.

W-LAN Radio Antenna Connection

Connect the reversed thread SMA plug of the antenna RF cable to the W-LAN jack on the expansion board.

For best 802.11a/b/g/n coverage and communication performance, connect WLAN MIMO antenna to all three antenna jacks.

Important Note: If only one antenna is used, always connect the antenna to the “1” jack of W-LAN.



Note

The connector type of all W-LAN jacks are reverse polarity reverse thread SMA. To secure the plug, turn counterclockwise. To release the plug, turn clockwise.

Recommended W-LAN antenna: PCTEL Multi-Band Mobile Low Profile MIMO Antenna PCTEL P.N: Z3352.

GPS Antenna Connection

The MW810 Mobile Workstation may be supplied with an optional internal module of Global Positioning System (GPS). Connect the cable connector of the GPS antenna to the GPS connector at the rear panel of the CPU Box, on one side, and to the connector of an active GPS antenna on the other side.

To install the GPS antenna to the vehicle, refer to the installation instructions of the antenna manufacturer.

Recommended antenna: PCTEL, 35dB stud mount antenna with jam nut. Motorola Solutions P.N: FAG5027.



Note

When a SBR-LS GPS Module is used, dead reckoning intelligence can be achieved only if vehicle speed (SPEED+ and SPEED-) and direction (FWD+, FWD-) inputs are connected to the auxiliary port of the CPU Box. For details see “AUX Port Connection” on page 40.

Video In Connection

Standard Composite CVBS video input. The MW810 Mobile Workstation is equipped with a BNC type connector to which a video camera can be connected. A BNC to RCA adapter (P.N: 5802810C07) is also available from Motorola Solutions.

Important Note: the Video In input is only supported in the “Extra Display, Video & I/O Expansion Board” expansion board option of the CPU Box.

USB Connections

The MW810 Mobile Workstation is equipped with standard USB (Universal Serial Bus) type A receptacles. The USB ports of the CPU Box are used for general purpose USB 2.0 and 3.0 devices. USB 3.0 ports can be identify by the blue plastic tab shown inside the connector and the USB 2.0 port by the white tab.

The USB 2.0 ports of the display units are usually used for connecting a QWERTY style keyboard or any other USB device.

USB devices are hot-pluggable. This means you can connect and disconnect devices while your operating system is running. The USB ports can connect to an external low, high, and full-speed USB devices. The USB ports support maximum transfer rate of 480 Mbit/s for USB 2 and 5 Gbit/s for USB 3.



- Do not use the right or left-side USB ports of the display for permanent connections. When driving, always disconnect and remove USB accessories from these ports to avoid disturbing the deployment of the vehicle air bags.
- A device connected to the USB port should not consume more than 0.5A. Otherwise, the device will not operate properly.
- Be aware, USB devices connected to the USB port should be compliant with the MW810 Win7 operating system. Otherwise the system will not operate properly.
- To keep the display unit sealed, cover the USB ports with the rubber plugs attached to each port.

Table 1 details the pin layout of a USB 2.0 port

Table 1
USB 2.0 Port - Pin Layout

Pin No.	Signal
1	VCC
2	USB-
3	USB+
4	GND

Serial Connections

The RS-232 ports are standard IBM[®] PC DB-9 male connectors. These ports can be used to connect an external radio modem, or any other serial device. The devices you connect to the Serial ports usually do not require installing a driver. However, if the serial device requires a software, please use the original driver provided with the device.

Table 2 details the pin layout of the RS-232 serial connection

Table 2
RS-232 Serial Connection - Pin Layout

Pin No.	Signal
1	DCD1
2	RX1
3	TX1
4	DTR1
5	GND
6	DSR1
7	RTS1
8	CTS1
9	RI1

eSATA Port

The External Serial Advanced Technology Attachment + power (eSATAp) is a combination connection for external storage devices. A single mSATA, eSATA or USB 2.0 device can be plugged into an eSATAp port.

LAN Connections

1000 Base-T Ethernet wire connections to support Local Area Network (LAN). The Ethernet connections are used for communication with Ethernet devices such as network cards, access points, storage, etc.

To connect the CPU Box to the network, connect one end of the LAN cable to the RJ-45 receptacle on the CPU Box and the other end to a network hub.

When the CPU Box is connected, the RJ-45 indicates as follows:

- Link LED Indicator - steady green when the system has an available connection to LAN.
- Active LED Indicator - blinks green when the system is accessing the LAN.

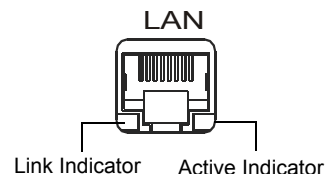

Table 3 details the pin layout of the 1000 Base-T Ethernet connection

Table 3
1000 Base-T Ethernet Connection - Pin Layout

Pin No.	Signal
1	DA+
2	DA-
3	DB+
4	DC+
5	DC-
6	DB-
7	DD+
8	DD-

Mic Line In Connection

The MW810 Mobile Workstation is equipped with a Audio In connector to which an external microphone can be connected.

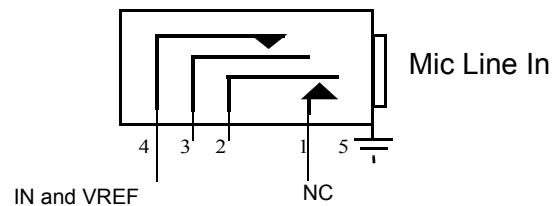

Audio Line Out Connection

The MW810 Mobile Workstation is equipped with an Stereo Audio Line Out connector to which external earphone can be connected or external speaker with a built-in amplifier.

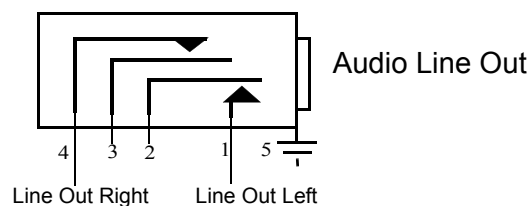

Power (PWR) Connection

The MW810 Mobile Workstation is equipped with two DC power cables and fuses, one for the CPU Box and the other for the display. To connect power to the MW810 Mobile Workstation units, refer to “Electrical Guidelines” on page 11.

Important Note: The MW810 Mobile Workstation default power system is 12V. In order to use the MW810 Mobile Workstation with 24VDC power system, the POWER SOURCE parameter in the CPU Codeplug must be changed to 24V. To change the POWER SOURCE parameter in the CPU Codeplug, refer to Motorola Solutions MW810 Mobile Workstation, R2.0, Administrator Guide (P.N: 6802988C42).

AUX Port Connection

The AUX port provides ignition sense connection to the MW810 Mobile Workstation.

The AUX port can also be used as a power supply of 5 to 27 VDC (pre-programmed Voltage) at a maximum current of 1.5A to any auxiliary equipment inside the vehicle.

The AUX port provides four predefined GPIO (the port can be set as input or output) and two GPO (output only) ports. The output Voltage can be pre-programmed to 5 to 27 VDC at a maximum current of 150mA.

To set the GPIO ports and power supply output in the CPU Codeplug, refer to Motorola Solutions MW810 Mobile Workstation, R2.0, Administrator Guide (P.N: 6802988C42).

The Low “0” input signal range is 0 to 0.2V and the High “1” input signal range is 3.3 to 33V.



When an I/O port is configured as an Input port, the external voltage must be supplied to that port via a 160 Ohm resistor to ensure proper operation.

For complete pin assignment of the AUX port, refer to Table 4.

Ignition Sense Connection

To install the ignition-sense cable between the AUX connector and the vehicle ignition line, carry out the following steps:

Step 1. Connect one end of the ignition-sense wire to pin 8 of the AUX connector, and the other end to the vehicle ignition switch.

Step 2. Connect pin 7 to the vehicle Ground.

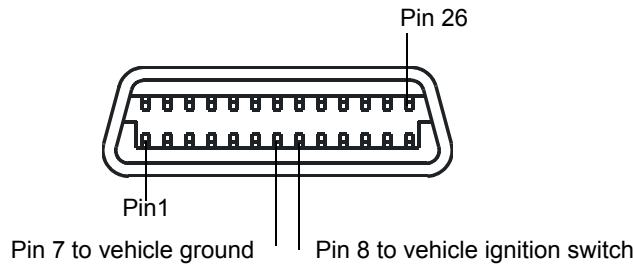

Figure 27
AUX Connection - Ignition Sense Pin-outs

Table 4
AUX Connection - Pin Layout

Pin No.	Signal	Description
1	SPEED+	Positive vehicle speed input signals
2	SPEED-	Negative vehicle speed input signals
3	FWD+	Forward/Backward drive direction input signals

Pin No.	Signal	Description
4	FWD-	Forward/Backward drive direction input signals
5	GPO1	General purpose output 1, with preset output voltage of 5 to 27V, Maximum current: 150mA
6	GPO2	General purpose output 2, with preset output voltage of 5 to 27V, Maximum current: 150mA
7	GND	Ground
8	IGN_SENSE	Input ignition power sense from ignition key
9	BIOS_RECOVERY#	Crisis BIOS boot-up input signal (active low signal). Used to boot the CPU Box from an external drive that connects to any of the USB ports
10	PROG_ENTER	Enable input signal for programming the embedded controller inside the CPU Box
11	GND	Ground
12	GND	Ground
13	GND	Ground
14	BATT OUT	Output power. Maximum 1 Amps. Output inhibits when CPU Box temperature is above operating range. The output power corresponds to the power that operates the CPU Box
15	BATT OUT	Identical to pin number 14
16	GPIO1	General purpose input/output 1, with preset output voltage of 5 to 27V Input High "1" Voltage: 3.3-33 VDC Input Low "0" Voltage: 0 - 02 VDC
17	GPIO2	General purpose input/output 2, with preset output voltage of 5 to 27V Input High "1" Voltage: 3.3 - 33 VDC Input Low "0" Voltage: 0 - 02 VDC
18	GPIO3	General purpose input/output 3, with preset output voltage of 5 to 27V Input High "1" Voltage: 3.3 - 33 VDC Input Low "0" Voltage: 0 - 02 VDC
19	GPIO4	General purpose input/output 4, with preset output voltage of 5 to 27V Input High "1" Voltage: 3.3 - 33VDC Input Low "0" Voltage: 0 - 02VDC
20	RX_EC	Data Input to the embedded controller of the CPU
21	TX_EC	Data Output from the embedded controller of the CPU
22	N.C	
23	N.C	
24	GND	Ground
25	5 - 27V	5 to 27V Power output. Maximum 1.5 Amps. Output is automatically disconnected when CPU Box temperature is exceeds operating range
26	5 - 27V	5 to 27V Power output. Maximum 1.5 Amps. Output is automatically disconnected when CPU Box temperature is exceeds operating range

Display 1 and 2 Connections



Note

To interface the MW810 CPU Box R2.0 to a legacy MW810 display use:

- CPU Box R2.0 to Display (60 pin to 50 pin) adaptor cable P.N: FKN0003
- CPU Box R2.0 to Display (60 pin to 36 pin) adaptor cable P.N: FKN00011

When interfacing a legacy display to the MW810 CPU Box R2.0, software installation is also required. (See MW810 Mobile Workstation, R2.0, Administrator Guide P.N 6802988C42.)

The DISPLAY 1 connector of the CPU Box can interface to a 3rd party LCD or CRT display by DVI or RGB connection. To interface to a 3rd party display, use CPU Box Splitter Cable P.N: FKN0009A.

The CPU Box graphics controller support resolutions up to 1280 x 1024 and the simultaneous operation of two monitors, the analog RGB (DISPLAY1 connection) and digital DVI (DISPLAY2 connection).



Note

The CPU Box graphic controller (Intel® HD Graphics 4000 Engine) supports resolutions up to 1280x1024. When using MW810 display, XGA resolution (1024 x 768) is recommended.



Caution

To avoid damage to the DISPLAY connectors on the rear panel of the CPU Box, connect the cable orientated to the right hand side (in reference to the cable molded rib).

The MW810 Mobile Workstation displays have available USB 2.0 ports supporting transfer rates up to 480 MB/s. When the CPU is connected to the old MW800 display, only USB 1.1 performance can be provided.

Table 5 details the pin layout of the DISPLAY 1 and 2 connection

Table 5
DISPLAY 2 Connection - Pin Layout

Pin No.	Signal
1	USB2P
2	USB2N
3	GND

Table 5
DISPLAY 2 Connection - Pin Layout

4	USB3TP4
5	USB3TN4
6	GND
7	USB3RP4
8	USB3RN4
9	GND
10	DVI_CLK#
11	DVI_CLK
12	GND
13	GND
14	DVI_D2#
15	DVI_D2
16	GND
17	GND
18	DVI_D0
19	DVI_D0#
20	N.C
21	N.C
22	GND
23	GND
24	GND
25	GND
26	GND
27	GND
28	GND
29	GND
30	GND
31	5V
32	GND
33	N.C
34	DDC_CLK
35	ON_BTN#
36	N.C
37	N.C
38	LINE_R

Table 5
DISPLAY 2 Connection - Pin Layout

39	LINE_R#
40	VSYNC
41	Sec disp.indication
42	GND
43	GND
44	GND
45	Blue
46	Green
47	Red
48	DVI_D1#
49	DVI_D1
50	Display cable detect 5V
51	HSYNC
52	SE_OUT#
53	N.C
54	N.C
55	N.C
56	HPD
57	DDC_DATA
58	N.C
59	GND
60	5V

Connection of CPU Box Splitter Cable

The CPU Box Splitter Cable (P.N: FKN0009) enables you to interface the MW810 Mobile Workstation CPU Box to a standard DVI or RGB display.

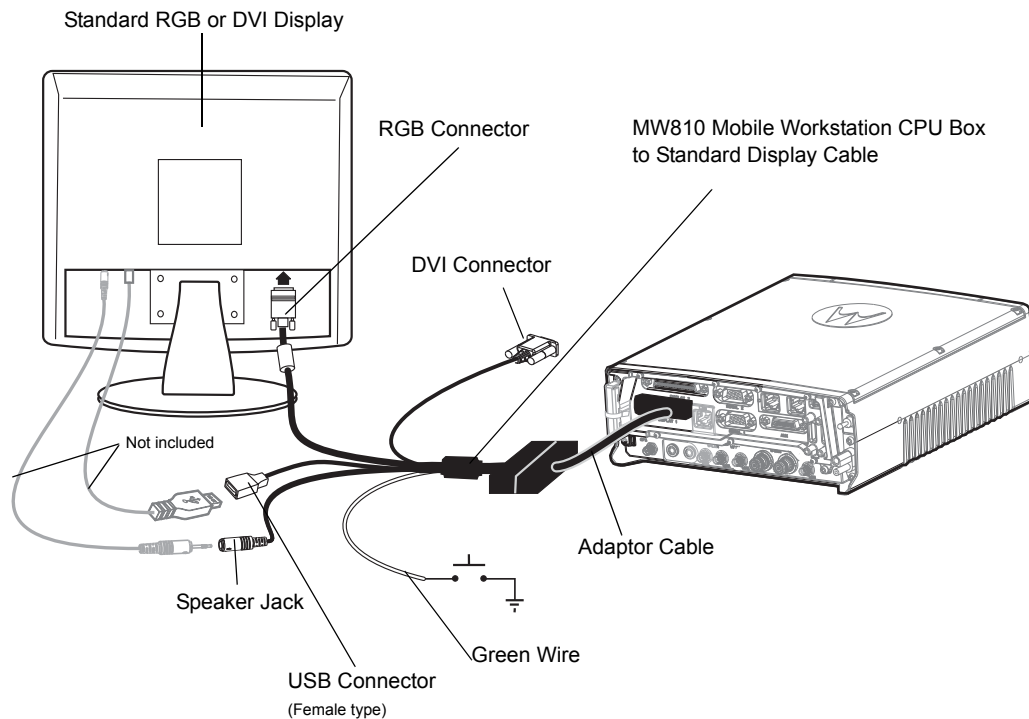

Figure 28
Connection of CPU Box Splitter Cable to a Standard Display

The following table describes the connectors of the MW810 CPU Box Standard RGB or DVI Display.

Connector	Description
RGB or DVI	RGB or DVI signals from the personal computer to display.
USB 2.0	USB communication between the CPU Box and a Standard RGB or DVI display. This connection also enables 5V to turn the display On/Off when the CPU Box is turned On/Off.
Speaker Jack	Audio from the CPU Box to display speaker.
Green Wire	Used when a 3ed party display is connected to MW810 CPU Box and the CPU Box is installed in a remote location inside the vehicle. In such configuration, turning the CPU Box On/Off during normal operation is hard or impossible. This green wire connects to an external push button that provides “ground” connection to the CPU Box. When “ground” is toggled, the button operates identically as the power button on the front panel of the CPU Box.



To avoid damage to the DISPLAY connectors on the rear panel of the CPU Box, connect the CPU Box Splitter Cable orientated to the right hand side (in reference to the cable molded rib).

Connection of MW810 Mobile Workstation Auxiliary Port to Vehicle Wiring

The Auxiliary cable with terminal block (FKN2008 or FKN8533) enables you to interface the MW810 Mobile Workstation CPU Box to the Vehicle Wiring. For terminal connections, refer to “AUX Connection - Pin Layout” on page 40.

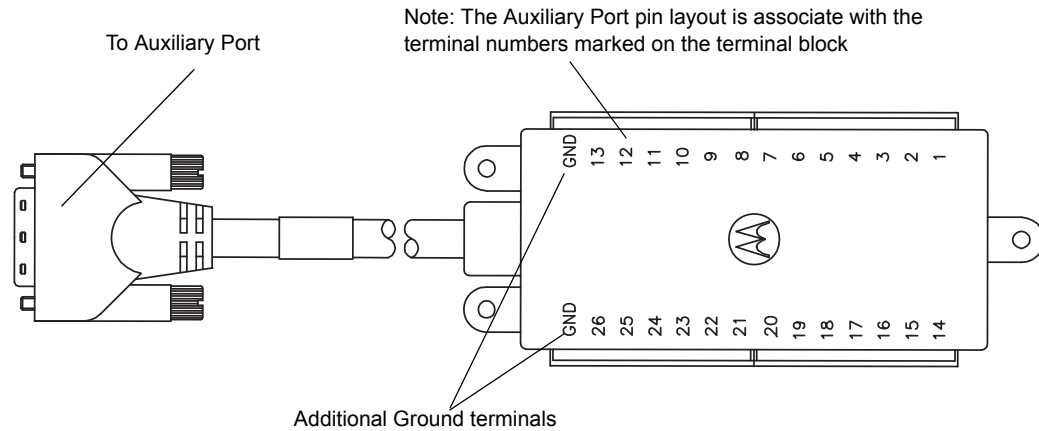

Figure 29
Auxiliary cable with terminal block (P.N: FKN8533)

Connection of ALPR Cameras

The ALPR Splitter Cable enable interfacing up to four PIPS ALPR cameras (P632 with LVDS interface) installed on a vehicle. For detailed installation and calibration procedure, camera cables and mounts, refer to PIPS Technology at: <http://www.pipstechnology.com/>. For cable connections to the CPU box, refer to Figure 30.

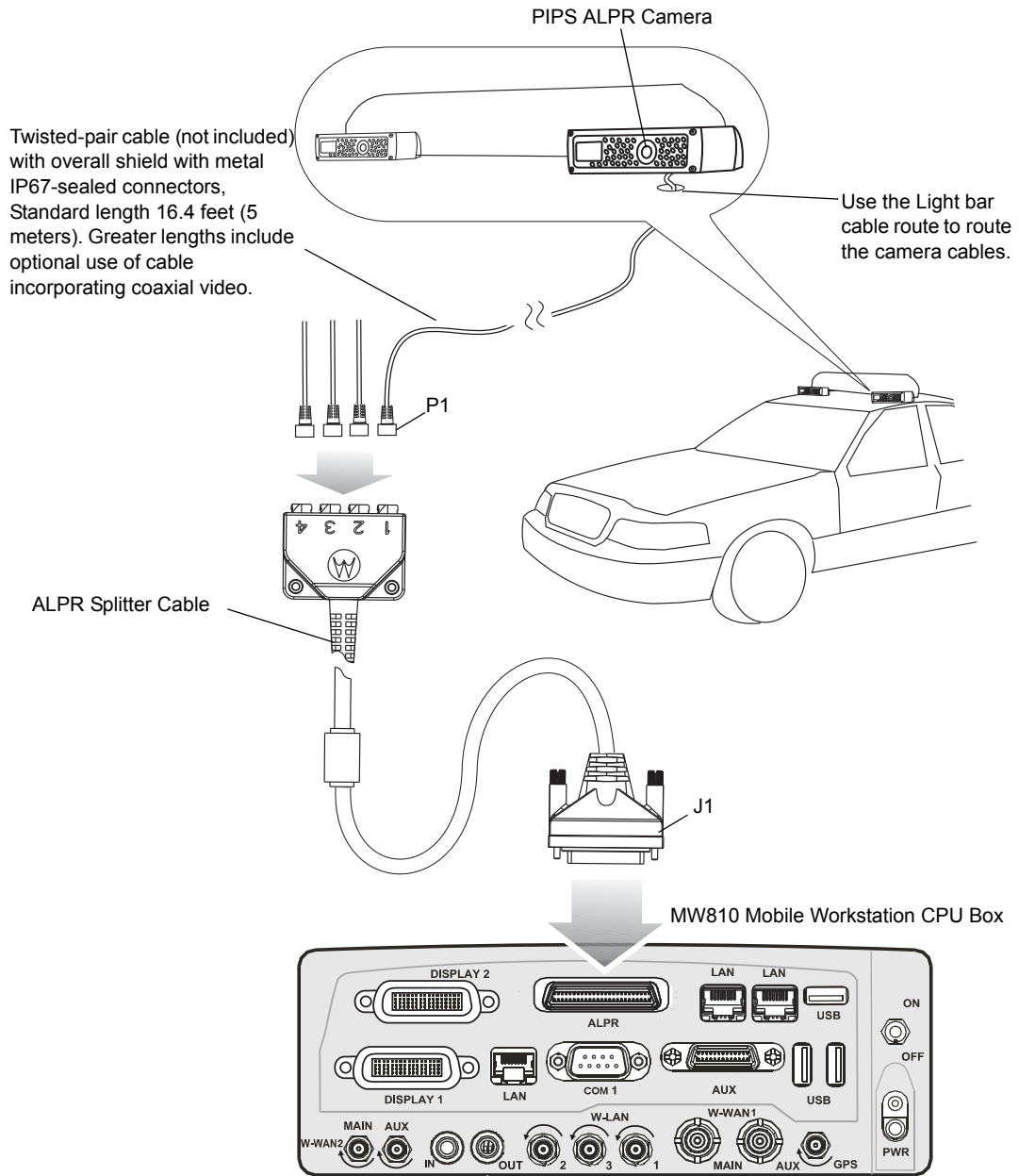

Figure 30
Connection of MW810 Mobile Workstation Auxiliary Port to Vehicle Wiring

Table 6 details the pin layout of the ALPR Connector.

Table 6
ALPR Connector Pin layout

J1 Pin #	Raw #	signal	Twisted Pair Group#	Conn P1	Conn P2	Conn P3	Conn P4
1	1	CAM3-LVDS-N2	1			6	
2	1	CAM3-LVDS-P2	1			7	
3	1	GND		NC	NC	NC	NC
4	1	CAM3-LVDS-N1	2			8	
5	1	CAM3-LVDS-P1	2			1	
6	1	GND	SH3			9	
7	1	CAM2-LVDS-N2	3		6		
8	1	CAM2-LVDS-P2	3		7		
9	1	GND		NC	NC	NC	NC
10	1	CAM2-LVDS-N1	4		8		
11	1	CAM2-LVDS-P1	4		1		
12	1	GND	SH2		9		
13	1	CAM1-LVDS-N2	5	6			
14	1	CAM1-LVDS-P2	5	7			
15	1	GND		NC	NC	NC	NC
16	1	CAM1-LVDS-N1	6	8			
17	1	CAM1-LVDS-P1	6	1			
18	1	GND	SH1	9			
19	1	CAM1-EXIST#		10			
20	1	PWR1		3			
21	1	PWR1		NC	NC	NC	NC
22	1	PWR2			3		
23	1	PWR2		NC	NC	NC	NC
24	1	PWR3				3	
25	1	PWR3		NC	NC	NC	NC
26	2	CAM4-LVDS-N2	7				6
27	2	CAM4-LVDS-P2	7				7
28	2	GND					
29	2	CAM4-LVDS-N1	8				8
30	2	CAM4-LVDS-P1	8				1
31	2	GND	SH4				9
32	2	CAM2-EXIST#			10		
33	2	CAM1-TX		2			
34	2	CAM1-RX		4			
35	2	CAM2-TX			2		
36	2	CAM2-RX			4		
37	2	CAM3-TX				2	
38	2	CAM3-RX				4	
39	2	CAM4-TX					2
40	2	CAM4-RX					4
41	2	CAM3-EXIST#				10	
42	2	CAM4-EXIST#					10
43	2	GND		5			
44	2	GND			5		
45	2	GND				5	
46	2	GND					5
47	2	GND		NC	NC	NC	NC
48	2	GND		NC	NC	NC	NC
49	2	PWR4					3
50	2	PWR4		NC	NC	NC	NC

Turning On the MW810 Mobile Workstation

Before powering ON the MW810 Mobile Workstation:

- Verify proper display to CPU cable connection on both sides.
- Verify keyboard connection to the display.
- Verify that the vehicle power system can supply at least 15 Amps.
- Check that the power cables are plugged into the power connectors of the CPU Box and the display.



Note

The main power switch on the CPU Box back panel (MAIN SWITCH) must be in OFF position before connecting to power supply source.

- Switch ON the main power switch (MAIN SWITCH) on the back panel of the CPU Box.

If the MW810 Mobile Workstation is connected through the ignition switch, insert the car key into the ignition switch and rotate it to ACC position, or start the engine, before powering ON.

To power the workstation, press the Power button on the front panel of the CPU Box, or press the Workstation Power button on the display.

Turn-on Modes

The MW810 Mobile Workstation has four optional turn-on modes using the ignition key and the Power buttons of the display or CPU Box. Setting an optional turn-on mode is performed by software application.

Using the Power Button or Ignition Key to Start the MW810 Mobile Workstation

This mode is the default workstation setting.

The MW810 Mobile Workstation can be turned ON by either one of the following methods:

1. Press the Power button of the CPU Box or Display, regardless of the ignition key position.
2. Turn ON the ignition switch.

The MW810 Mobile Workstation can be turned OFF by either one of the following methods:

1. When the ignition switch is in OFF position, press the Power button of the CPU Box or Display. Note that when the ignition switch is in ON position, the Power buttons are ignored.
2. Turn OFF the MW810 Mobile Workstation via the Operating System (OS).

Using the Power Button and Ignition Key to Start the MW810 Mobile Workstation

The MW810 Mobile Workstation can be turned ON by the following method:

1. Turn ON the ignition switch.

2. Press the Power button of the CPU Box or Display to turn ON the MW810 Mobile Workstation.

The MW810 Mobile Workstation can be turned OFF by the following method:

1. Press the Power button of the CPU Box or Display to turn OFF the MW810 Mobile Workstation.
2. Turn OFF the ignition switch.
3. Turn OFF the MW810 Mobile Workstation via the OS.

Using the Power Button to Start the MW810 Mobile Workstation

The MW810 Mobile Workstation can be turned ON by the following method:

1. Press the Power button on the CPU Box or Display, regardless of ignition key position.

The MW810 Mobile Workstation can be turned OFF by either one of the following method:

1. Press the Power button of the CPU Box or Display.
2. Turn OFF the MW810 Mobile Workstation via the OS.

Using the Ignition Key to Start the MW810 Mobile Workstation

The MW810 Mobile Workstation can be turned ON by the following method:

1. Turn ON the ignition key. Note that the CPU Box and Display Power buttons are disabled.

The MW810 Mobile Workstation can be turned OFF by either one of the following methods:

1. Turn OFF the ignition key.

Turn OFF the MW810 Mobile Workstation via the OS. Note that in order to turn ON the MW810 Mobile Workstation, the ignition key should be turned to OFF position, and switched back to ON.

Turning Off the MW810 Mobile Workstation

To turn Off the workstation, press the CPU Box or display Power button momentarily. The workstation displays the Windows shut-down dialog box. Remember to save important information before turning OFF the MW810 Mobile Workstation.

The MW810 Mobile Workstation automatically turns OFF as a result of the following events:

- Extreme temperatures
- Discharged vehicle battery
- Pressing the Power button on the CPU Box or display for more than six seconds

In critical conditions or during maintenance, the workstation may be powered OFF by turning the main power switch on the CPU Box back panel.



Turning OFF the main power switch or disconnecting the power cable when the MW810 Mobile Workstation is running may seriously damage your operating system or your Hard Disk Drive.

Storage

Important Note: Maximum storage period in shipping package is six months. To refresh storage, assemble the workstation and run Disk Defragmenter (*Go to: Start->Programs->Accessories->System Tools->Disk Defragmenter*)

Appendix A

Installation, Configuration and Calibration of GPS Dead Reckoning

Dead reckoning is a feature that allows a vehicle navigation system to continue estimating the vehicle location when the GPS system inside the vehicle is unable to receive signals from GPS satellites. Dead reckoning is performed by monitoring the speed and direction of the vehicle to keep track of position relative to the last known location.

Installing the GPS Gyro

The gyro tells the navigation system (U-blox GPS module) when your vehicle makes a turn. The gyro is set for horizontal mounting of the CPU Box at the factory. However, an angle-mounted CPU Box can not track turns if the gyro is not set properly.

When the MW810 is ordered with a GPS Dead Reckoning option, the gyro wired to the U-blox GPS module needs to be situated in accordance to the installation position of the CPU Box.

The gyro sensor should be mounted perpendicular to the navigation plane. The following sections show 4 optional gyro orientations for all CPU Box installation positions. Note that once the CPU Box is open, no tools are required for changing the gyro position.



When installing the CPU Box, do not exceed + -5 degrees tilt angle from **all vehicle axis**. Installing the CPU Box over + -5 degrees tilt angle from one or more of the vehicle axis may result in gyro reading error while in DR mode.

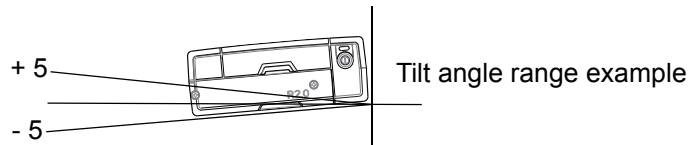

Vertical Installation - front panel facing up

Step 1. Remove the six screws that secure the top cover of the CPU Box.

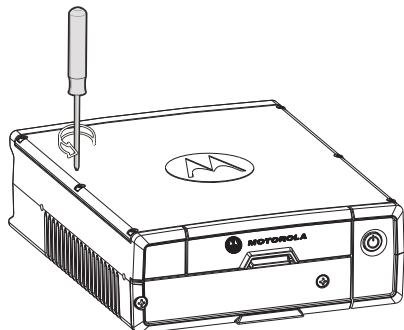

Step 2. Orient and mount the Gyro unit as shown in the picture.

Step 3. Fasten the six screws (Torque: 5 Inch-Pound) that secure the top cover of the CPU Box.

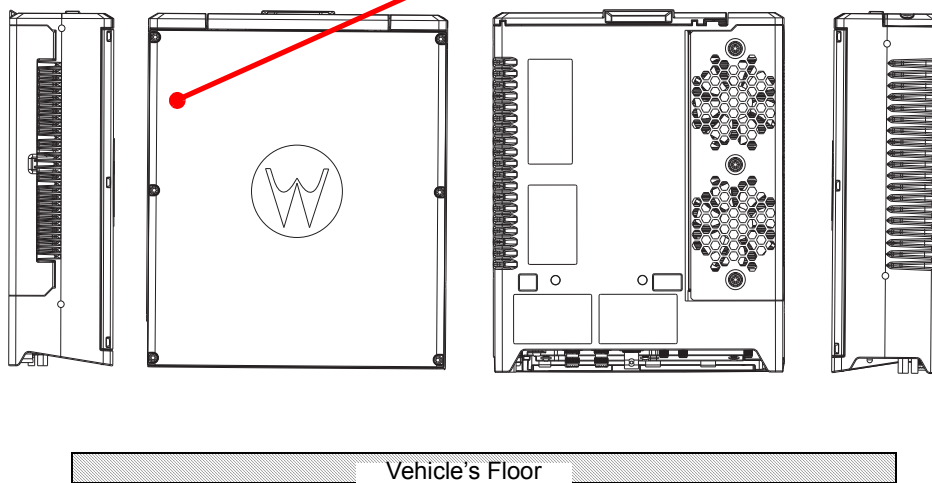
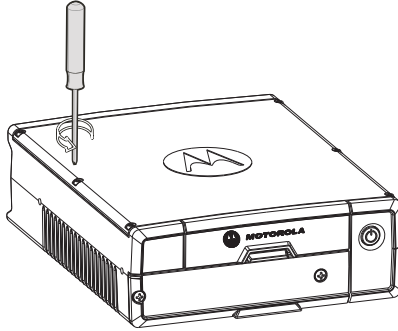

Figure 31
GPS Dead Reckoning - vertical Installation (front panel facing up)

Vertical Installation - back panel facing up

Step 1. Remove the six screws that secure the top cover of the CPU Box.



Step 2. Orient and mount the Gyro unit as shown in the picture.

Step 3. Fasten the six screws (Torque 5 Inch-Pound) that secure the top cover of the CPU Box.

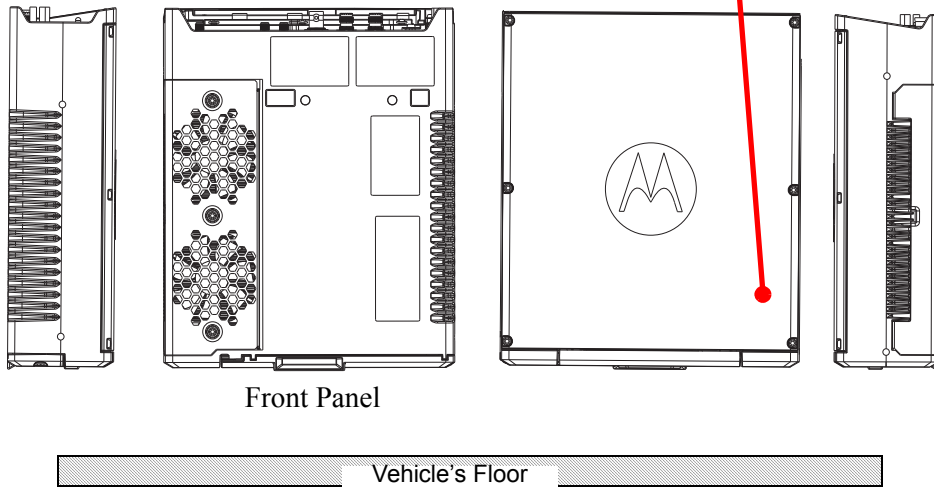
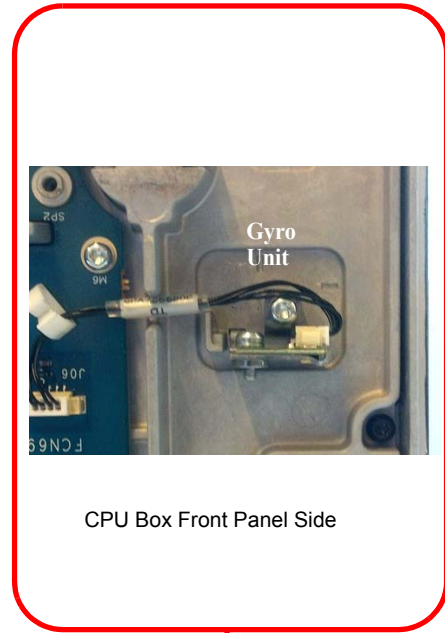
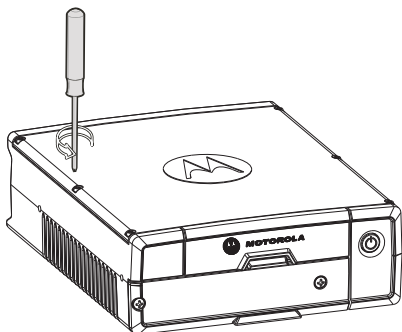

Figure 32
GPS Dead Reckoning - Vertical Installation (back panel facing up)

Vertical Installation - CPU back panel facing sideways

Step 1. Remove the six screws that secure the top cover of the CPU Box.



Step 2. Orient and mount the Gyro unit as shown in the picture.

Step 3. Fasten the six screws (5 Inch-Pound) that secure the top cover of the CPU Box.

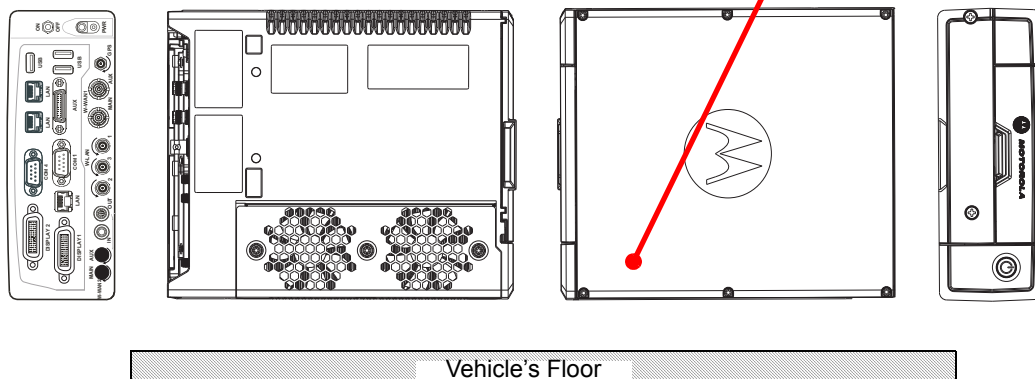
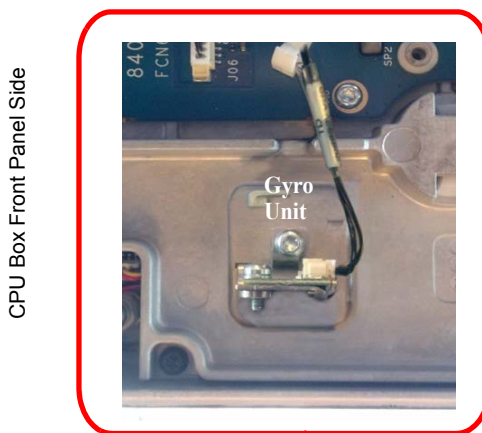
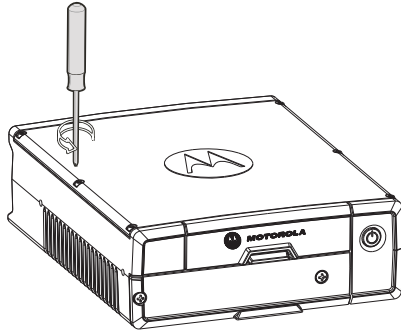

Figure 33
GPS Dead Reckoning - Vertical Installation (CPU back panel facing sideways)

Horizontal Installation of CPU Box (Default Configuration)

Step 1. Remove the six screws that secure the top cover of the CPU Box.



Step 2. Orient the Gyro unit as shown the picture.

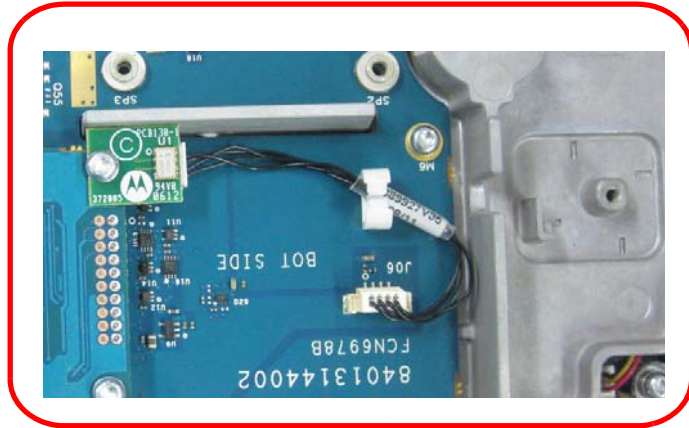

Step 2. Orient and mount the Gyro unit as shown in the picture.

Step 3. Fasten the six screws (Torque 5 Inch-Pound) that secure the top cover of the CPU Box.

CPU Box Front Panel Side

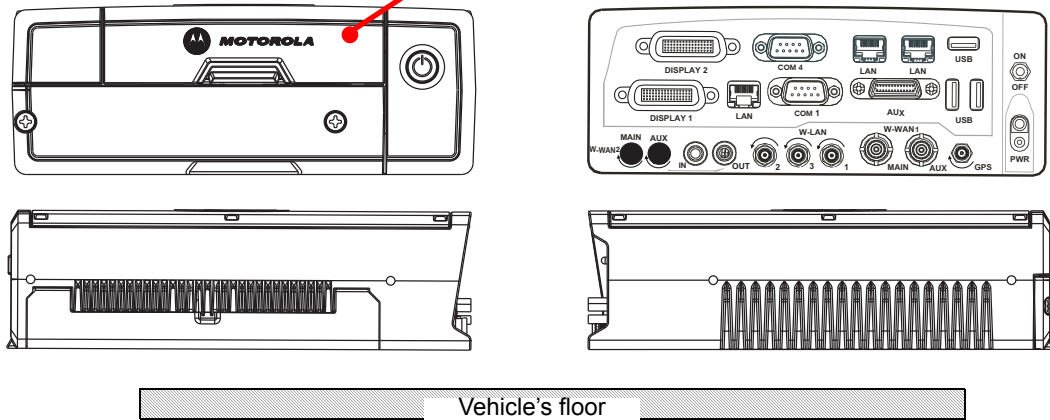

Figure 34
GPS Dead Reckoning - Horizontal installation of CPU Box

Unsupported CPU Box positions

IMPORTANT: Do not install the CPU Box in the following orientations when using the GPS Dead Reckoning option in the MW8100.

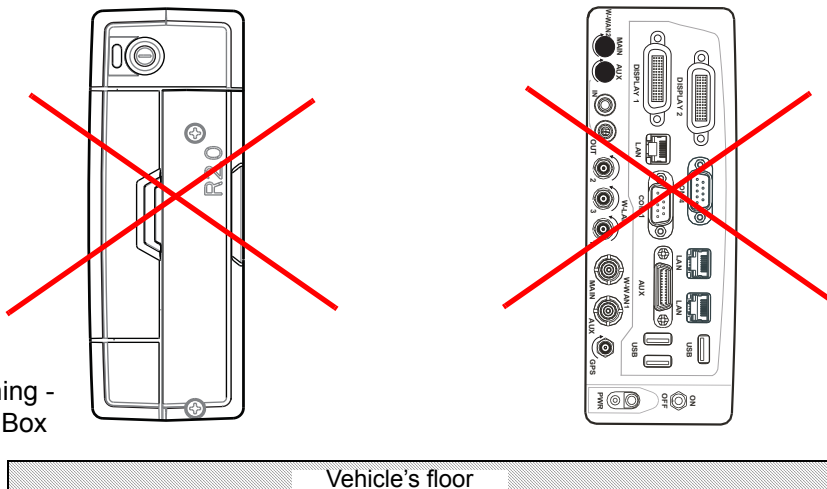

Figure 35
GPS Dead Reckoning -
Unsupported CPU Box
positions

Vehicle wire connections

The GPS Dead Reckoning navigation system connects to the vehicle's reverse signal wires (or reverse light) and the speed signals. This connection signals the navigation system when the vehicle is traveling forward or in reverse. See "GPS Dead Reckoning - Vehicle wire connections" on page 59..

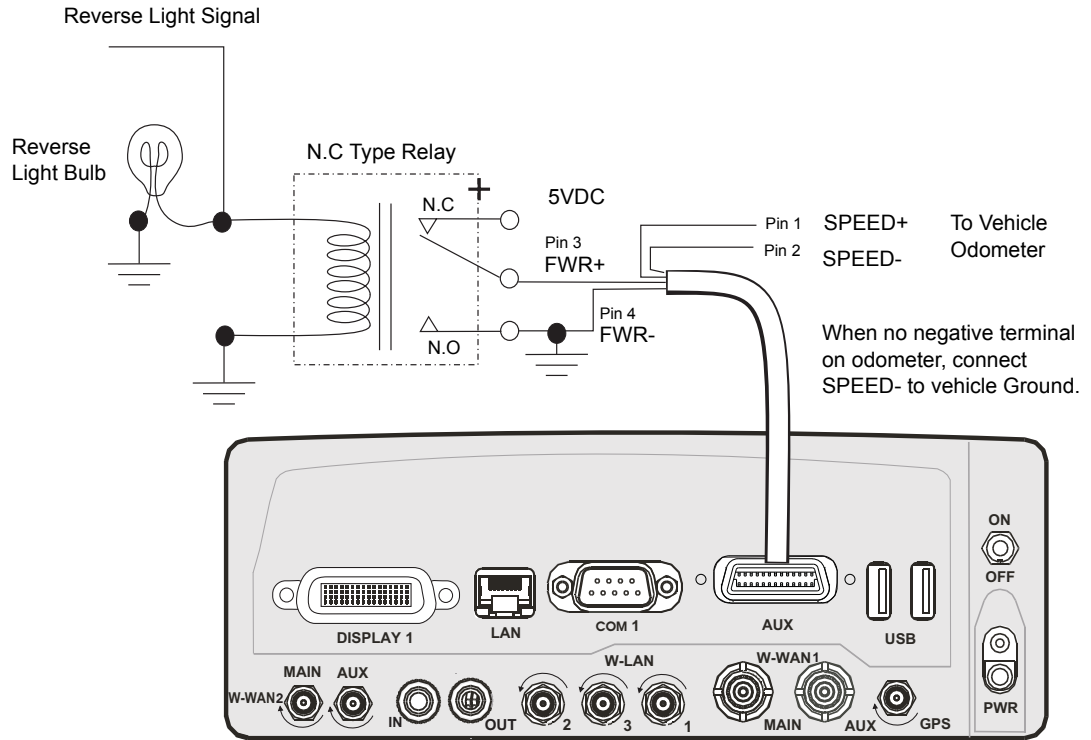

Figure 36
GPS Dead Reckoning - Vehicle wire connections

U-Blox U-Center Configuration

The u-center GPS Evaluation Software provides a powerful tool for evaluation, performance analysis and configuration of u-blox GPS receivers. u-blox GPS receivers can be configured using the u-center Evaluation Software.

To configure the u-blox GPS receiver, perform the following steps:

Step 1. Download the U-Center application from: http://www.u-blox.com/products/u_center.html.

Step 2. Install the U-Center application on the MW810.

Step 3. Click *START > Programs > U-Blox Products > Tools > U-Center Application* to run the U-Center application.

Step 4. From the application toolbar, click the “Configuration View Window” button . The left window pane enables to navigate to the configuration setting screens.

Step 5. From the left window pane, select *UBX > CFG (Config) > EKF (EKF Settings)*.

Step 6. Check the “EKF Enabled”, Clear Calibration Data, Clear Temperature Table options and click the  Send button to save.

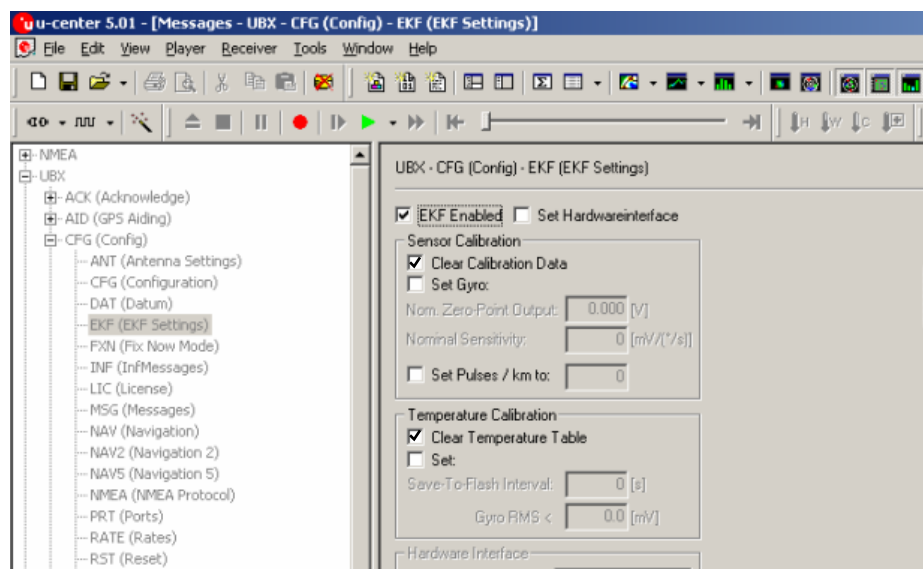

Step 7. From the left window pane, select *UBX > CFG (Config) > PRT (Ports)*.

Step 8. Set “Protocol in” and “Protocol out” to “0+1 - UBX+NMEA”.

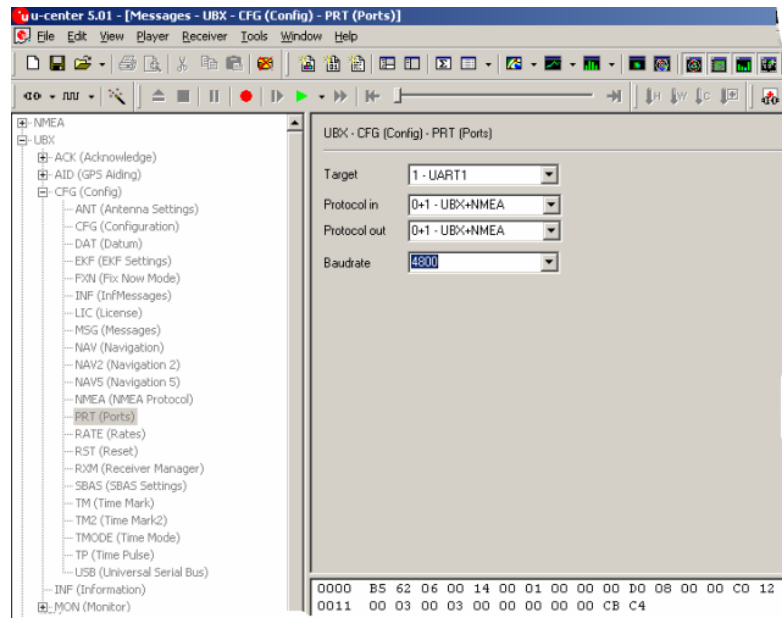



Step 9. From the left window pane, select *UBX > CFG (Config) > MSG (Messages)*.

Step 10. Check “UART1” and “UART2” options.

Step 11. Select the first NMEA message from the “Message” drop list and click the  Send button to save.

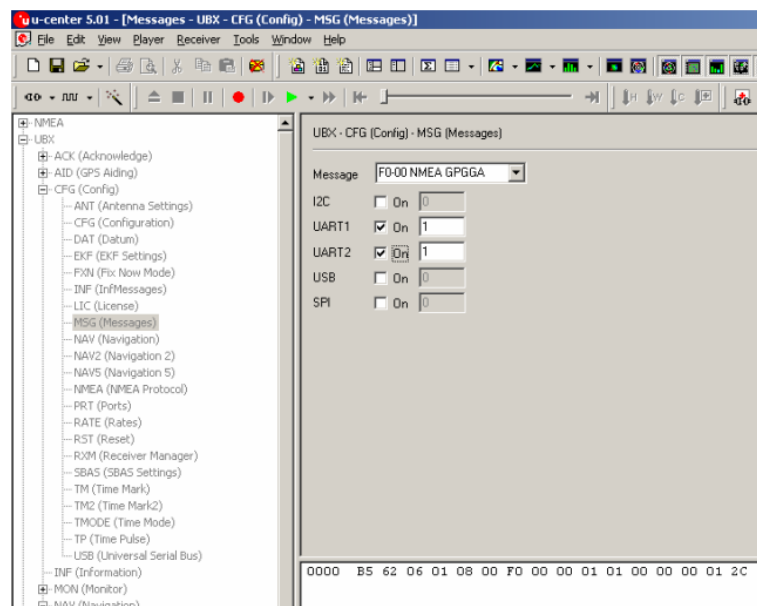
Step 12. Repeat Step 11. for all remaining NMEA messages in the drop list.



Step 13. Select the first NAV-EKFSTATUS message from the “Message” drop list and click the  Send button to save.

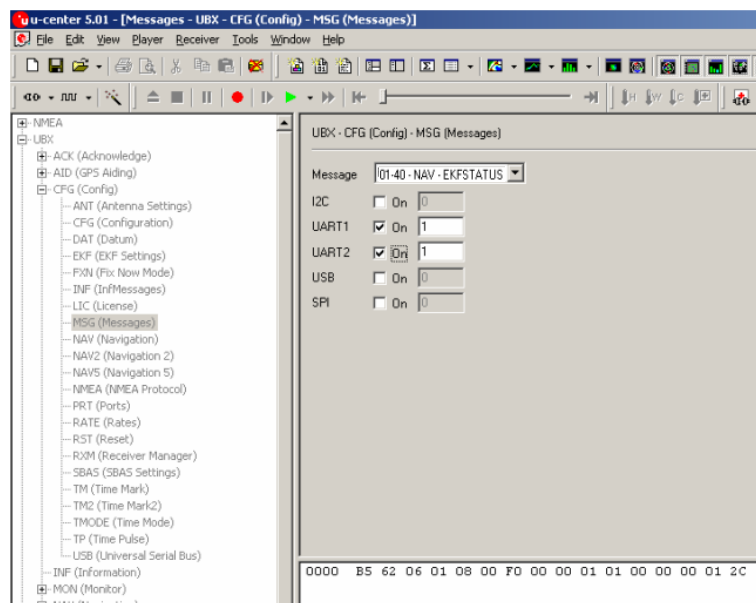

Step 14. From the left side window, select *UBX > CFG (Config) > CFG (Configuration)*.

Step 15. Check "Save current configuration" and "Devices" options and click the  Send button to save.

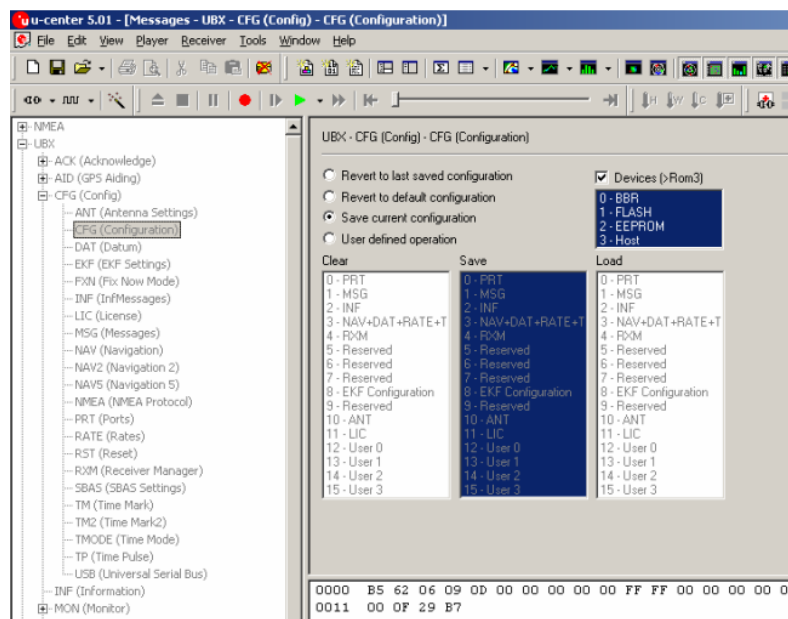

Step 16. From the left window pane, select *UBX > CFG (Config) > EKF (EKF Settings)*.

Step 17. Check the “Clear the Calibration Data” option and click the  Send button to save (see “Check the “EKF Enabled”, Clear Calibration Data, Clear Temperature Table options and click the button to save.” on page 60.).

Step 18. Verify the wiring connection:

- a. From the left side window, select *UBX > NAV > EKFSTATUS*.
- b. Verify that the Direction change when in reverse gear
- c. Verify that the gyro reading shows readings around 33000
- d. Drive few hundred yards and verify speed ticks reading.

Note: To calibrate the GPS, refer to “Automatic Calibration” on page 64.

Step 19. To verify calibration, view the percentage values on the below screen. When clearing calibration (see Step 17), the screen should show 0.00% (click on Poll icon  for the updated value). After a successful calibration, the percentage value should show 80% or higher.

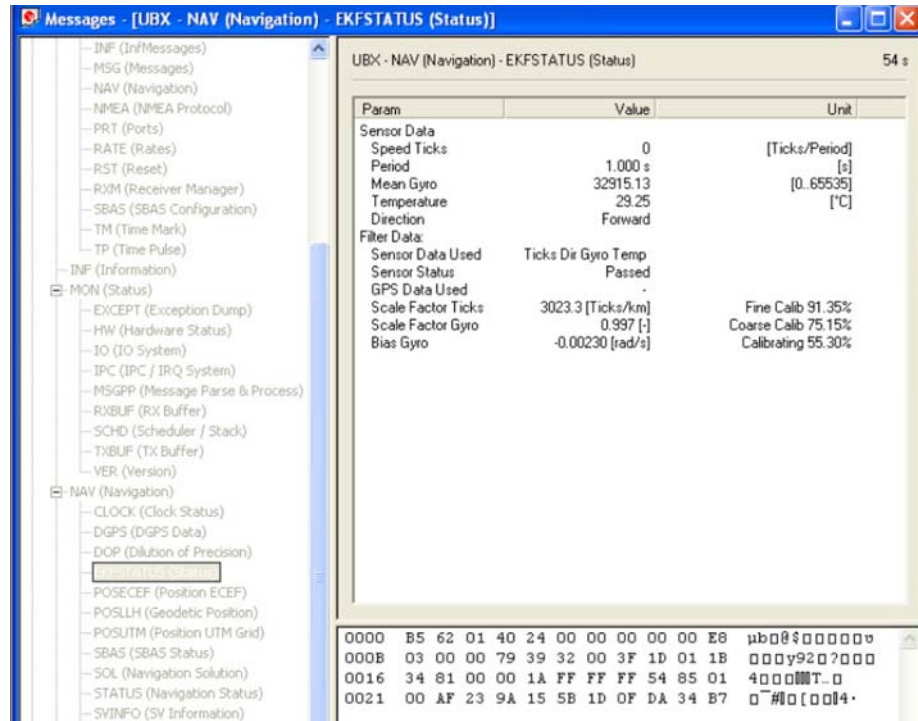

Step 20. Before loading the user application, set the unit for NMEA messages as follows: From the left window pane, select *UBX > CFG (Config) > EKF (EKF Settings)*. Set the “Protocol out” to NMEA only unless your application can filter out the UBX commands. The baud rate should match your application requirements. click the  button to save.

Automatic Calibration

Basics

Automatic Calibration takes place continuously & transparently during periods of good GPS reception while driving around.

Benefits

- Accuracy improves over time of operation
- Fully compensates effects from aging (aging effects of gyroscope)
- Temperature compensation enables high accuracy at different temperatures

GPS measurements (PVT) are used as calibration references for

Gyroscope turn rate sensor

- Offset (Recognize straight routes)
- Scaling factor (Adjust sharpness of turns)
- Temperature compensation to gyroscope scaling factor and offset

Odometer pulses

- Scaling factor (Relationship between pulse rate and speed)

Installation in a new vehicle

- With a new GPS receiver installed in a new vehicle, the accuracy is only moderately good until sufficient calibration data has been collected, e.g. during a first drive
- With the time, continuous calibration results in continuous improvement of dead reckoning accuracy

Small discontinuities

- Small discontinuities, like deviating wheel diameters from exchanging tires (summer vs. snow tires), will be balanced out by ongoing automatic calibration

Significant changes

- Applicable if the Sensor-based GPS receiver is transferred to a different vehicle or if a different gyroscope is connected.
- Calibration parameters must be reset. A UBX-message (UBX-CFG-EKF) is available to invoke the reset.
- For optimum navigation performance the new system needs some one-time learning time and distance for calibrating the various sensors inputs.
- Normally, a good level of calibration is achieved very quickly with a single short road trip where GPS reception is good.
- Odometer pulses are calibrated with driving a distance (scaling factor)

- Gyroscope is calibrated while driving straight (offset) with making turns (scaling factor)

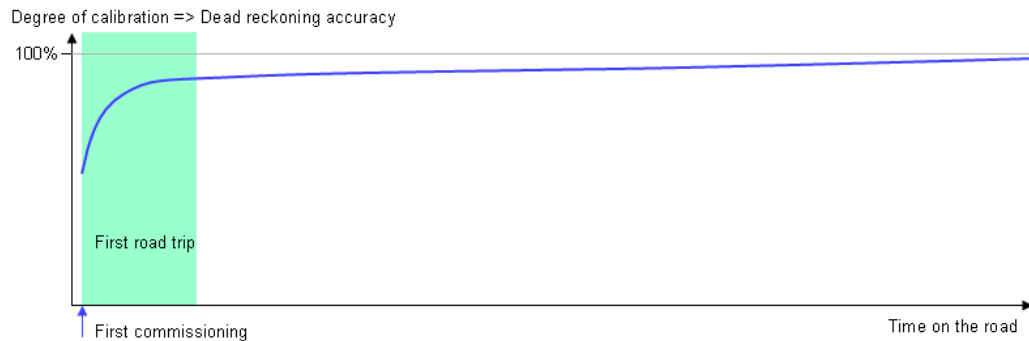

Automatic Calibration – Testing Environment

Driving recommendation if high accuracy is required very quickly, e.g. for product testing and benchmarking:

The following driving directions are recommended to achieve an efficient calibration so dead reckoning yields high accuracy after a short period of time.

	Find a place with open sky view e.g. big parking site		
	Stand still for 90 seconds to start GPS receiver until valid position is calculated		Exceed 60 km/h for at least 10 sec
	Drive straight route for 500m, at least 40 km/h		Make at least two sharp left turns (90° or more)
	Drive curves and straight segments for ca. 5 minutes with good visibility in any order		Make at least two sharp right turns (90° or more)

- The above instructions result in a calibration status within the shortest period of time. Should traffic, road and regulatory conditions not allow achieving this track, the time until optimum calibration will increase. However navigation results are already satisfactory after a relatively short driving distance and time.
- The above instructions shall not be made a rule towards any end user. They shall only be applied in a product testing environment where sufficient care is taken that these driving instructions can be carried out without creating any risk of accidents or violation of regulations.

This page intentionally left blank

Appendix B -Accessories

Secondary 12.1" Display R2.0 Standard Brightness

FLN1019	12.1" XGA 500NIT Display, 60 Pin, US
FLN1062	12.1" XGA 500NIT Display, 60 Pin, with Bluetooth Radio, US
FLN1064	12.1" XGA 500NIT Display, 60 Pin, with Screws, US
FLN1069	12.1" XGA 500NIT Display, 60 Pin, with Bluetooth Radio and Screws, US
FLN1019	12.1" XGA 500NIT Display, 60 Pin, EU REG LBL
FLN1062	12.1" XGA 500NIT Display, 60 Pin, with Bluetooth Radio, EU
FLN1064	12.1" XGA 500NIT Display, 60 Pin, with Screws, EU
FLN1069	12.1" XGA 500NIT Display, 60 Pin, With Bluetooth Radio and Screws, EU

Secondary 12.1" Display R2.0 High Brightness

FLN1018	12.1" XGA 1500NIT Display, 60 Pin, US
FLN1063	12.1" XGA 1500NIT Display, 60 Pin, US
FLN1065	12.1" XGA 1500NIT Display, 60 Pin, with Screws, US
FLN1068	12.1" XGA 1500NIT Display, 60 Pin, with Bluetooth Radio and Screws, US
FLN1018	12.1" XGA 1500NIT Display, 60 Pin, EU
FLN1063	12.1" XGA 1500NIT Display, 60 Pin, with Bluetooth Radio, EU
FLN1065	12.1" XGA 1500NIT Display, 60 Pin, with Screws
FLN1068	12.1" XGA 1500NIT Display, 60 Pin, with Bluetooth Radio and Screws, EU

Secondary 8.4" Display

FLN3669A	8.4" SVGA 800NIT Display, 50Pin, US
FLN3669AE	8.4" SVGA 800NIT Display, 50Pin, EU

Cables CPU Port (60 Pin), DVI to MW810 12.1" Display R2.0 (60 Pin)

FKN0006	1.5M (4.9FT) MW810 CPU Box to Display Cable, 60 to 60 Pin, DVI
FKN0005	3.0M (9.8FT) MW810 CPU Box to Display Cable, 60 to 60 Pin, DVI
FKN0004	5.0M (16.4FT) MW810 CPU Box to Display Cable, 60 to 60 Pin, DVI

Adaptor Cable, CPU2.0 (60 Pin) to R1.2 Display Cable (50 Pin)

FKN0003	0.2M (0.66FT) Adaptor Cable CPU Box to Display R1.2, 60 to 50 Pin
---------	---

Adaptor Cable, CPU2.0 (60 Pin) to R1.2 Display Cable (36 Pin)

FKN00011	0.2M (0.66FT) Adaptor Cable CPU Box to Display R1.2, 60 to 36 Pin
----------	---

Adaptor Cable, CPU1.2 (50 Pin) to Display R2.0 Cable (60 Pin)

FKN00010	0.2M (0.66FT) Adaptor Cable CPU R1.2 to Display R2.0, 50 to 60 Pin
----------	--

Cables RGB, CPU (36Pin) TO 8.4" R1.2 (50 Pin)

FKN8455	3.5M(11.5FT) MW810 8.4" Display to CPU Box Cable, RGB, Right Side Driving
FKN8456	5.0M (16.4FT) MW810 8.4" Display to CPU Box, Cable, RGB, Right Side Driving
FKN8456	6.0M (19.68FT) MW810 8.4" Display to CPU Box, Cable, RGB, Right Side Driving

FKN8555 5.0M (16.4FT) MW810 8.4" Display to CPU Box, Cable, RGB, Left Side Driving

FKN8555 6.0M MW810 8.4" Display to CPU Box, Cable, RGB, Left Side Driving

Cables DVI, CPU (50Pin) TO 8.4" R1.2 (50Pin) Options

FKN8457 3.5M(11.5FT) MW810 8.4" Display to CPU Box Cable, DVI, Right Side Driving

FKN8458 5.0M(16.4FT) MW810 8.4" Display to CPU Box, Cable, DVI, Right Side Driving

FKN8556 5.0M(16.4FT) MW810 8.4" Display to CPU Box, Cable, DVI, Left Side Driving

Cable, SPLITTER CPU SIDE 60 Pin, 30 cm

FKN0009 Cable Splitter CPU 60 Pin, 30 cm

Cable, SPLITTER Display SIDE 60 Pin

FKN0008 0.30M (0.98FT) Cable Splitter CPU 60 Pin, Display SIDE

ALPR Splitter Cable - From ALPR Expansion Board to SLATE ALPR Camera Cable

FKN8577 Cable Splitter ALPR 50 Pin

Keyboard

FTN0017 Keyboard, USB, Backlit, US

FTN0016 Keyboard, USB, Backlit, UK

FTN0015 Keyboard French Canadian

FTN0014 Keyboard, USB, Backlit, French

FTN0013 Keyboard, USB, Backlit, German

FTN0012 Keyboard, USB, Backlit, Cyrillic / English

FTN0011 Keyboard, USB, Backlit, Swedish

FTN0003 Keyboard, USB, Backlit, Turkish / English

FTN0002 Keyboard, USB, Backlit, Czech

FTN0010 Keyboard, Backlit, USB, ARABIC/English

FTN0009 Keyboard, Backlit, USB, BELGIAN/FRANCH

FTN0008 Keyboard, Backlit, USB, SPANISH

FTN0007 Keyboard, Backlit, USB, ITALIAN

FTN0006 Keyboard, USB, Backlit, CANADIAN FR QUEBEC

FTN0018 Keyboard, USB, Backlit, Swiss French

FTN0005 Keyboard, USB, Backlit, Chinese

FTN0004 Keyboard, USB, Backlit, Hebrew

Additional Interface Cables

FKN0007 AUX Cable with TB, and 2 Extended Current GPO, 0.63M (25 INCH), MW810,

FTN7099 HDMI Adaptor

FKN8524 Filtered DC Cable for MW810

FKN8201 Keyboard Extender Cable, USB 6FT

FKN8564 HSYNC VSYNC Level Shift Cable 36 to 36 Pin, Active

FKN8565 HSYNC VSYNC Level Shift Cable 50 to 36 Pin, Active

FKN8338	9.6FT (3.0M) AUX Cable 26/Open
FKN8533	AUX Cable with CONNECT BLOCK, 63 cm (25 INCH), MW810
FKN8340	External SPKR Cable Adaptor
FKN8449	3.5M (11.5FT) MW810 12.1" Display to RGB STD CPU
FKN8450	3.5M (11.5FT) MW810 CPU 36 Pin to RGB STD Display
FKN8454	3.5M (11.5FT) MW810 12.1" Display to DVI STD CPU
FKN8544	3.5M (11.5FT) MW810 CPU 50 Pin to DVI STD Display
FKN8547	3.5M (11.5FT) MW810 8.4" Display to DVI STD CPU

Storage Device, Spare Parts

FLN0012	HDD, 500GB with Compartment
FLN0013	SSD, 256GB with Compartment

EXTERNAL MIC

FLN3676	ASSY, KIT, WIRED_MICROPHONE, _3M
FTN7561	ASSY, MIC, WIRED_MICROPHONE, _7M

Radios Antennae

FAG5030	WLAN Antenna, 3X3 MIMO, 12FT
FAG5027	GPS, Antenna (PCTEL)
FAG5024	WLAN Antenna, 1X1 SHARKFIN, 12FT
FAG5033	GPS, Antenna (AMP)
FAG5029	WWAN1 GOBI5K MAIN/DIVERSITY
FAG0002	WWAN1 SIERRA MC7750 MAIN/DIVERSITY

Other ACCESSORIES

8.4" Display

FLN3669	Display. 8.4" SVGA 800NIT, Screws EEN, US/Canada
FLN3669	Display. 8.4" SVGA 800NIT, Screws EEN, EUROPE

Legacy 12.1" Display R1.1

FLN3991	12.1" XGA 1200NIT, US/CAN
FLN3993	12.1" XGA 1200NIT, with Bluetooth Radio, US/Canada
FLN3995	12.1" XGA 1200NIT, with Screws, US/Canada
FLN3997	12.1" XGA 1200NIT, with Screws and BT, US/Canada
FLN3999	12.1" XGA 400NIT, US/CAN
FLN4001	12.1" XGA 400NIT, with Bluetooth Radio, US/Canada
FLN4003	12.1" XGA 400NIT, with Screws, US/Canada
FLN4033	12.1" XGA 400NIT, with Screws and B.T, US/Canada
FLN3991	12.1" XGA 1200NIT, EU
FLN3993	12.1" XGA 1200NIT, with Bluetooth, EU
FLN3995	12.1" XGA 1200NIT, with Screws, EU

FLN3997	12.1" XGA 1200NIT, with Screws and B.T, EU
FLN3999	12.1" XGA 400NIT, EU
FLN4001	12.1" XGA 400NIT, with Bluetooth, EU
FLN4003	12.1" XGA 400NIT, with Screws, EU
FLN4033	12.1" XGA 400NIT, with Screws and B.T, EU

Cables for 12.1" Primary Display (MW810 CPU to MW810 Display)

FKN8446	1.5M (4.9FT) MW810 Display to CPU Box Cable, RGB
FKN8447	3.0M (9.8FT) MW810 Display to CPU Box Cable, RGB
FKN8448	5.0M (16.4FT) MW810 Display to CPU Box Cable, RGB

Cables for Secondary MW810 CPU Port (DVI) to MW810 12.1" Display

FKN8451	1.5M(4.9FT) MW810 Display to CPU Box Cable, DVI
FKN8452	3.0M(9.8FT) MW810 Display to CPU Box Cable, DVI
FKN8453	5.0M(16.4FT) MW810 Display to CPU Box Cable, DVI

Cable for ALPR Exp. Board DVI Port (36 Pin) to MW810 12.1" Display (50 Pin)

FKN8584	5.0M(16.4FT) 36Pin CPU-50Pin Display Cable, DVI
---------	---

Cables for CPU RGB Port (36 Pin) to MW810 8.4" Display (50 Pin)

FKN8455	3.5M(11.5FT) MW810 8.4" Display to CPU Box Cable, RGB, Right Side Driving
FKN8456	5.0M(16.4FT) MW810 8.4" Display to CPU Box, Cable, RGB, Right Side Driving
FKN8555	5.0M(16.4FT) MW810 8.4" Display to CPU Box, Cable, RGB, Left Side Driving

Cables for CPU DVI Port (50 Pin) to MW810 8.4" Display (50 Pin)

FKN8457	3.5M(11.5FT) MW810 8.4" Display to CPU Box Cable, DVI, Right Side Driving
FKN8458	5.0M(16.4FT) MW810 8.4" Display to CPU Box, Cable, DVI, Right Side Driving
FKN8556	5.0M(16.4FT) MW810 8.4" Display to CPU Box, Cable, DVI, Left Side Driving

Mounting Trunnion

FHN7006A	MOUNTING TRUNNION, MW810
----------	--------------------------

Acronyms

A	Ampere
ACK	Positive (Acknowledgment)
ALPR	Automatic License Plate Recognition
AUX	Auxiliary
CPU	Central Processing Unit
CVBS	Composite Video Blanking and Sync
DC	Direct Current
DRAM	Dynamic Random Access Memory
DVI	Digital Video Interface
eSATA	External Serial Advanced Technology Attachment
FCC	Federal Communications Commission
GHz	GigaHertz
GPIO	General Purpose Input/Output
GPRS	General Packet Radio Service
GPS	Global Positioning System
I/O	Input/Output
LAN	Local Area Network
LCD	Liquid Crystal Display
LP	Liquid Propane
LTE	Long Term Evolution
MB	Megabyte

MDR	Mini D Ribbon
MW	Mobile Workstation
NIT	Near Infrared Transmission (also cd/m2, a measure of luminance)
NTSC	National Television System Committee
OS	Operating System
PA	Power Amplifier
PAL	Phase Alternation Line
PC	Personal Computer
PCMCIA	Personal Computer Memory Card International Association
PCI	Peripheral Component Interconnect
PRM	Portable Radio Modem
PWR	Power
RF	Radio Frequency
RFI	Radio Frequency Interference
SIM	Subscriber Identity Module
TTL	Transistor-Transistor Logic
UHF	Ultra High Frequency
UL	Underwriter's Laboratories
USB	Universal Serial Bus
V	Volt
VDC	Volts Direct Current
WLAN	Wireless Local Area Network
WWAN	Wireless Wide Area Network
XGA	Extended Video Graphics Array



Motorola, Inc.
1301 E. Algonquin Road,
Schaumburg, IL 60196

Inside the USA, Americas and Canada call Motorola System Support Center at 1-800 221-7144

For Europe, the Middle East and Africa, call +420 533 336 123

MOTOROLA and the Stylized M Logo are registered in the U.S. Patent and Trademark Office. All other product or service names are the property of their respective owners.

© Motorola, Inc. 2012.

6802988C56-A

